

MARINA COAST WATER DISTRICT
2020 URBAN WATER MANAGEMENT PLAN



Prepared by

Schaaf & Wheeler
CONSULTING CIVIL ENGINEERS

May 2021

This page intentionally left blank.

MARINA COAST WATER DISTRICT
2020 URBAN WATER MANAGEMENT PLAN



Board of Directors

Jan Shriner, President
Thomas Moore, Vice-President
Herbert Cortez
Gail Morton
Matt Zefferman

Prepared by

Schaaf & Wheeler
CONSULTING CIVIL ENGINEERS
3 QUAIL RUN CIRCLE, SUITE 101
SALINAS, CA 93907

Public Review Draft.
For review only.

Andrew A. Sterbenz, PE
License C 69703

05/20/2021

May 2021

Version History

Version Date	Revision Number	By	Comments
05/07/2021	0	Andrew Sterbenz, PE	Initial Draft
05/12/2021	1	Andrew Sterbenz, PE	Administrative Draft
05/20/2021	2	Andrew Sterbenz, PE	Public Review Draft

Table of Contents

Section 1 - Plan Summary	1
1.1 Purpose and Authority	1
1.2 System Description	1
1.3 Water Demands	3
1.4 Water Supplies	5
1.5 Water Supply Reliability	7
1.6 Conservation and Demand Management	7
Section 2 - Plan Preparation	8
2.1 Background	8
2.2 Public Participation in Plan Development	8
2.3 Agency Coordination	9
2.4 Plan Adoption.....	9
2.5 Plan Implementation	10
2.6 Completed UWMP Checklist.....	10
Section 3 - System Description	11
3.1 District Location, History and Operations	11
3.1.1 Central Marina Service Area	11
3.1.2 Ord Community Service Area	12
3.2 Climate	16
3.3 Population.....	17
3.4 Demographic Factors	18
Section 4 - Water Demands.....	19
4.1 Current Water Use.....	19
4.2 Projected Water Demands.....	20
4.2.1 Central Marina Service Area Demands	20
4.2.2 Ord Community Service Area Demands	21
4.2.3 Demand Projection Methodology	22
4.2.4 Summary of Demand Projections	25
4.3 Projected Water Demand by Sector	26
4.3.1 Lower Income Housing Demands	26
4.4 Water Conservation Baseline and Targets	28
4.4.1 Plan for Meeting Urban Conservation Targets	31
Section 5 - Water Supplies	34
5.1 Water Sources and Water Rights	34
5.2 Groundwater.....	36
5.2.1 Salinas Valley Groundwater Basin	36
5.2.2 Sustainable Groundwater Management Act	44
5.2.3 Basin Management.....	47
5.2.4 Integrated Regional Water Management Plan	48
5.2.5 Seawater Intrusion	49
5.2.6 Groundwater Contamination and Control.....	55
5.2.7 Salinas Valley Water Project	58
5.3 Water Transfer and Exchange Opportunities	59
5.4 Future Water Supply	60

5.4.1	Regional Urban Water Augmentation for the Ord Community.....	61
5.4.2	Surface Water Supplies.....	63
5.4.3	Stormwater Capture	64
5.4.4	Future Water Supply Assessments and Written Verifications of Supply	64
5.5	Recycled Water	65
5.5.1	Tertiary Treated Recycling Systems.....	65
5.5.2	Pure Water Monterey Project.....	67
5.6	Desalinated Water	71
5.6.1	Existing Desalination Facilities	71
5.6.2	Planned Desalination Facilities.....	71
Section 6 -	Water Supply Reliability and Water Shortage Contingency Planning	75
6.1	Water Supply Reliability - Single and Multiple Dry Years	75
6.2	Water Quality Impacts on Reliability.....	76
6.3	Water Quality Monitoring.....	77
6.4	Water Production System Reliability.....	78
6.5	Water Shortage Contingency Plan	78
6.5.1	Actions in the Event of a Catastrophic Interruption	79
6.5.2	Stages of Action, Mandatory Provisions, Reduction Methods.....	79
6.5.3	Penalties or Charges for Excessive Use.....	80
6.5.4	Revenue and Expenditure Impacts.....	81
6.5.5	Mechanism to Determine Actual Water Use Reductions	81
6.6	Seismic Risks to Water Supply	81
6.7	Drought Planning	82
6.8	Annual Water Supply and Demand Assessment.....	82
6.8.1	Evaluation Criteria	82
6.8.2	Water Supply	82
6.8.3	Current Year Unconstrained Customer Demand	82
6.8.4	Current Year Supply	83
6.8.5	Infrastructure Considerations.....	83
6.8.6	Other Factors.....	83
Section 7 -	Conservation and Demand Management Measures.....	84
7.1	Introduction	84
7.2	Demand Management Measures Implementation.....	84
7.2.1	Water Waste Prevention Ordinances	87
7.2.2	Metering.....	87
7.2.3	Conservation Pricing.....	87
7.2.4	Public Education and Outreach.....	88
7.2.5	Programs to Assess and Manage Distribution System Real Loss.....	88
7.2.6	Water Conservation Program Coordination and Staffing Support	89
7.2.7	Water Survey Programs for Residential Customers	89
7.2.8	Residential Plumbing Retrofits	89
7.2.9	Residential Ultra-Low Flow Toilet Replacement Programs.....	90
7.2.10	High-Efficiency Washing Machine Rebate Programs	90
7.2.11	Commercial, Industrial, and Institutional Accounts	90
7.2.12	Landscape Conservation Programs and Incentives.....	91
7.3	Planned Implementation to Achieve Water Use Targets	92

Appendices

- A. Resolution of Urban Water Management Plan Adoption
- B. References
- C. Land Use Forecast and Water Demand Projections by Jurisdiction
- D. Notices and Letters to Public Agencies
- E. Technical Memoranda
 - 1. District Population Estimate, dated 4/26/2021
 - 2. Water Allocations by Jurisdiction, dated 4/30/2021
 - 3. MCWRA Zones of Benefit and Assessment, dated 4/30/2021
 - 4. MCWD Seismic Risk Assessment. 5/14/2021
- F. Water Shortage Contingency Plan with Resolution of Adoption
- G. DWR Urban Water Management Plan Checklist
- H. Standardized Data Tables and SB X7-7 Verification Form
- I. Voluntary Reporting of Energy Intensity
- J. Comments Received on the Draft Plan

List of Tables

Table i	Acronyms Used in this Report.....	vi
Table ii	Units of Measure Used in this Report	vii
Table 1.1	Historic and Projected Population	1
Table 1.2	Projected Water Demand by Jurisdiction (afy).....	4
Table 1.3	Subbasins within the Salinas Valley Groundwater Basin.....	5
Table 2.1	Coordination with Appropriate Agencies	9
Table 3.1	Local Evapotranspiration Rates (inches)	17
Table 3.2	Historic Population	17
Table 3.3	Projected Population by Service Area	17
Table 4.1	Water Deliveries in 2015	19
Table 4.2	Water Deliveries in 2020	19
Table 4.3	Water Supply Assessments Used to Update the UWMP.....	22
Table 4.4	Water Demand Factors Applied in the UWMP	24
Table 4.5	Water Demand by Jurisdiction (afy).....	25
Table 4.6	Water Demand by Sector (afy)	26
Table 4.7	Lower Income Housing Demands (afy).....	28
Table 4.8	Per Capita Water Demands.....	30
Table 4.9	District Baseline and Targets	31
Table 4.10	Projected Per Capita Water Demands.....	31
Table 4.11	Per Capita Water Demand, 2011-2020	32
Table 5.1	Groundwater Production (acre-feet)	35
Table 5.2	DWR Subbasins within the Salinas Valley Groundwater Basin	36
Table 5.3	Ord Community Groundwater Shortfalls	61
Table 5.4	Projected Demand by Source (afy).....	61
Table 5.5	Recycled Water Allocations (afy).....	63
Table 5.6	Non-Potable Water Demand Projections (ac-ft/yr)	67
Table 6.1	Multiple Dry-Year Demand Adjustment Factors	76
Table 6.2	Water Demands in Single and Multiple Dry Years	76
Table 6.3	Water Shortage Contingency Plan - Stages of Action.....	80
Table 6.4	Water Shortage Contingency – Penalties and Charges.....	80
Table 6.5	Potential Revenue Impacts of Implementation of WSCP.....	81
Table 7.1	Summary of DMM Implementation	85
Table 7.2	Conservation Pricing Tiers (2021).....	87
Table 7.3	Current Rebates.....	92

List of Figures

Figure 1.1 MCWD Service Areas	2
Figure 1.2 Water Use, 2010 - 2020.....	3
Figure 1.3 Population and Per Capita Usage	4
Figure 1.4 Groundwater Basins and Sustainability Agencies.....	6
Figure 3.1 MCWD Vicinity Map.....	14
Figure 3.2 MCWD Service Areas	15
Figure 3.3 Local Climate Averages	16
Figure 4.1 Population and Per Capita Usage	32
Figure 5.1 Monterey County Groundwater Basins and Sub-Basins	37
Figure 5.2 Sub-Basin Boundaries and MCWD Wells and Service Areas	38
Figure 5.3 MCWRA-designated Subareas of the Salinas Valley Groundwater Basin	40
Figure 5.4 Groundwater Isoclines in the Pressure and East Side Basins.....	43
Figure 5.5 Groundwater Sustainability Agencies	45
Figure 5.6 Historic Seawater Intrusion in the 180-ft Aquifer.....	51
Figure 5.7 Historic Seawater Intrusion in the 400-ft Aquifer.....	52
Figure 5.8 Dune Sand Aquifer and 180-Foot Aquifer Chloride Concentration Data.....	53
Figure 5.9 Groundwater Contamination Plumes	57
Figure 5.10 Salinas Valley Groundwater Pumping, 1995-2019.....	59
Figure 5.11 Pure Water Monterey Schematic (partial).....	69
Figure 5.12 Recycled Water Systems	70
Figure 5.13 Existing and Potential Desalination Facilities.....	74
Figure 7.1 Conservation Spending and Indoor Water Demand.....	86
Figure 7.2 Conservation Spending and Outdoor Water Demand	86

Table i. Acronyms Used in this Report

Acronym	Description
afy, ac-ft/yr	Acre-feet/year
ccf, hcf	Hundred cubic feet
gpd	Gallons per day
gpcd	Gallons per capita day, or gallons per person per day
mgd	Million gallons per day
BMP	Best management practice
CASGEM	California Statewide Groundwater Elevation Monitoring
CAW, CalAm	California American Water Company
CCR	California Code of Regulations
CEQA	California Environmental Quality Act
CPUC	California Public Utilities Commission
CSUMB	California State University – Monterey Bay
CWC	California Water Code
DDW	SWRCB Division of Drinking Water
DMM	Demand management measure
DWR	California Department of Water Resources
FORA	Fort Ord Reuse Authority
GSA	Groundwater Sustainability Agency
GSP	Groundwater Sustainability Plan
LAFCO	Local Agency Formation Commission
M1W	Monterey One Water (formerly the Monterey Regional Water Pollution Control Agency)
MCWD, District	Marina Coast Water District
MCWRA	Monterey County Water Resources Agency
MPWMD	Monterey Peninsula Water Management District
OMC	Ord Military Community
POM	Presidio of Monterey
PWM	Pure Water Monterey Project
RUWAP	Regional Urban Water Augmentation Project
SB	California Senate Bill
SGMA	Sustainable Groundwater Management Act
SRDP	Salinas River Diversion Project
SVWP	Salinas Valley Water Project
SVBGSA	Salinas Valley Basin Groundwater Sustainability Agency
SVGB	Salinas Valley Groundwater Basin
SWRCB	State Water Resources Control Board
UCMBEST	University of California Monterey Bay Education, Science and Technology Center
UWMP	Urban Water Management Plan

Table ii. Units of Measure Used in this Report

Unit	Equals
1 acre-foot	= 43,560 cubic feet = 325,851 gallons
1 cubic foot	= 7.48 gallons
1 CCF	= 100 cubic feet = 748 gallons
1 MGD	= 1,000,000 gallons/day = 1,120 acre-feet / year

Section 1 - Plan Summary

1.1 Purpose and Authority

The California Water Code, Division 6, Part 2.6, Section 10610 et. seq. (California Urban Water Management Planning Act) requires any municipal water supplier serving over 3,000 connections or 3,000 acre-feet of water per year (afy) to prepare an urban water management plan.

In adopting the Urban Water Management Planning Act, the state declared as policy that:

- a) The management of urban water demand and efficient use of water shall be actively pursued to protect both the people of the state and their water resources;
- b) The management of urban water demands and efficient use of urban water supplies shall be a guiding criterion in public decisions;
- c) Urban water suppliers shall be required to develop water management plans to actively pursue the efficient use of available supplies.

1.2 System Description

The Marina Coast Water District is located in Monterey County, on the coast of Monterey Bay at the northwest end of the Salinas Valley. The District's jurisdictional service area is 10.3 square miles, encompassing the City of Marina and the occupied portions of the former Fort Ord. The District has a 2.2 square mile sphere of influence immediately north of its service area. The remaining redevelopment parcels within the former Fort Ord are considered a future study area (see Figure 1.1). The District has two service areas, Central Marina which is the portion of the City outside the former Fort Ord, and the Ord Community within the former Army base. The Ord Community includes portions of the Cities of Marina, Seaside, Del Rey Oaks and Monterey, as well as unincorporated portions of Monterey County. California State University and the University of California each have lands and facilities within the Ord Community.

The District served only the City of Marina until 1994, when Fort Ord closed and the District was selected to take over the water and wastewater systems within the base. The population served by MCWD is projected to more than double once the former Fort Ord is fully redeveloped, as shown in Table 1.1.

Table 1.1 Historic and Projected Population

Year	1990	2000	2010	2020	2030	2040
Population	26,436	33,813	30,480	36,646	58,012	73,183

Figure 1.1 MCWD Service Areas

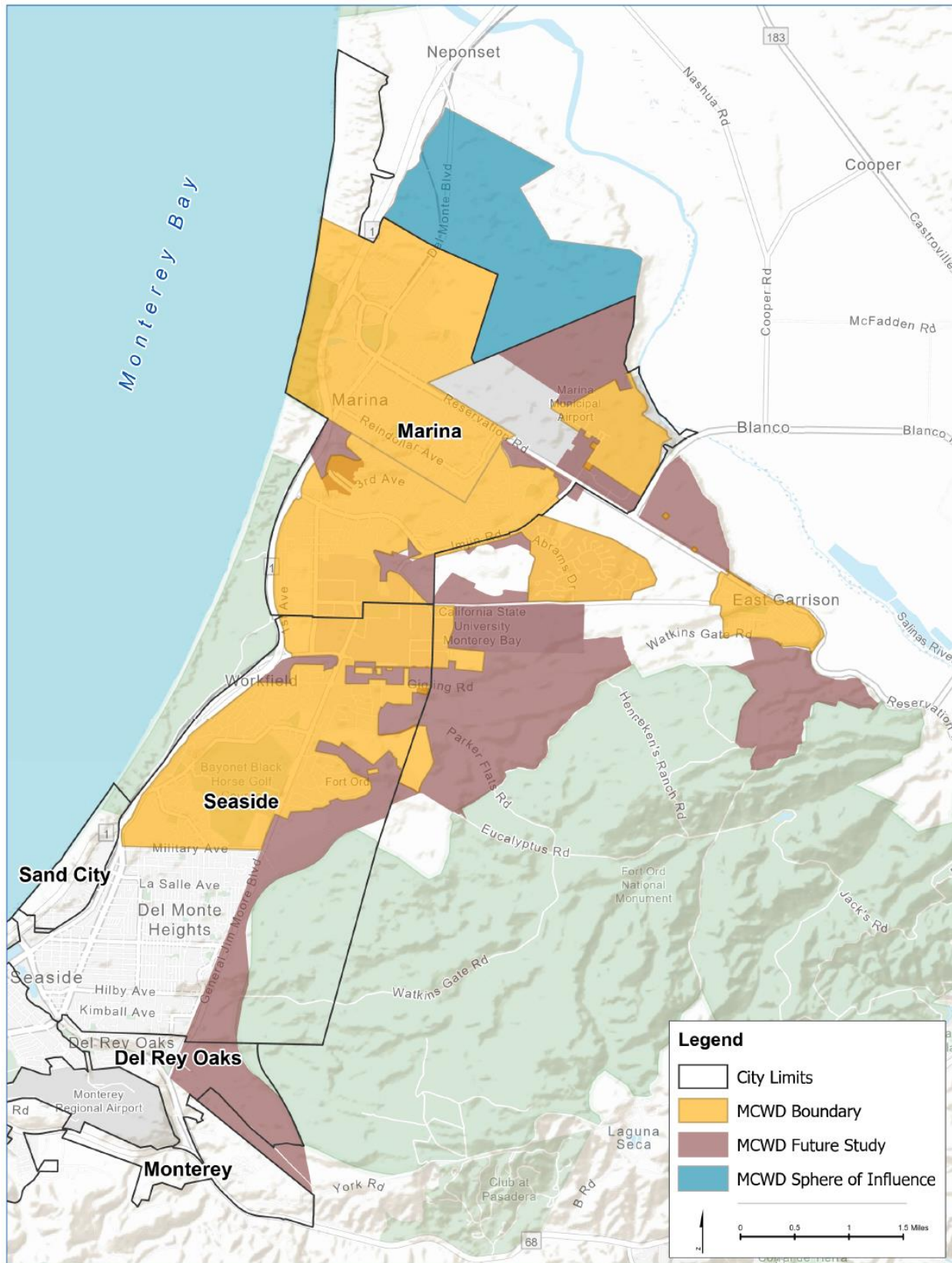

1.3 Water Demands

The District currently supplies approximately 3,300 acre-feet/year (afy), or an average 3 million gallons per day. The demands for the last decade are shown in Figure 1.2. California’s drought of record was the period 2012-2017, and the year 2013 was the driest on record for the Salinas Valley. As expected, water demand increased in 2013, mainly for landscape irrigation. In 2014 mandatory water use restrictions were imposed, and they remained in place until 2016. A significant amount of “hard” water conservation improvements were made during the drought (fixture replacements, turf and landscape replacements), such that the post-drought water use has not rebounded to pre-drought levels, even though the population was steadily increasing during this period (see Figure 1.3). The District-wide average water demand is currently 80 gallons per capita per day (gpcd), which is significantly under the State goal of 100 gpcd and the District’s 2020 conservation target of 117 gpcd.

Figure 1.2 Water Use, 2010 - 2020¹

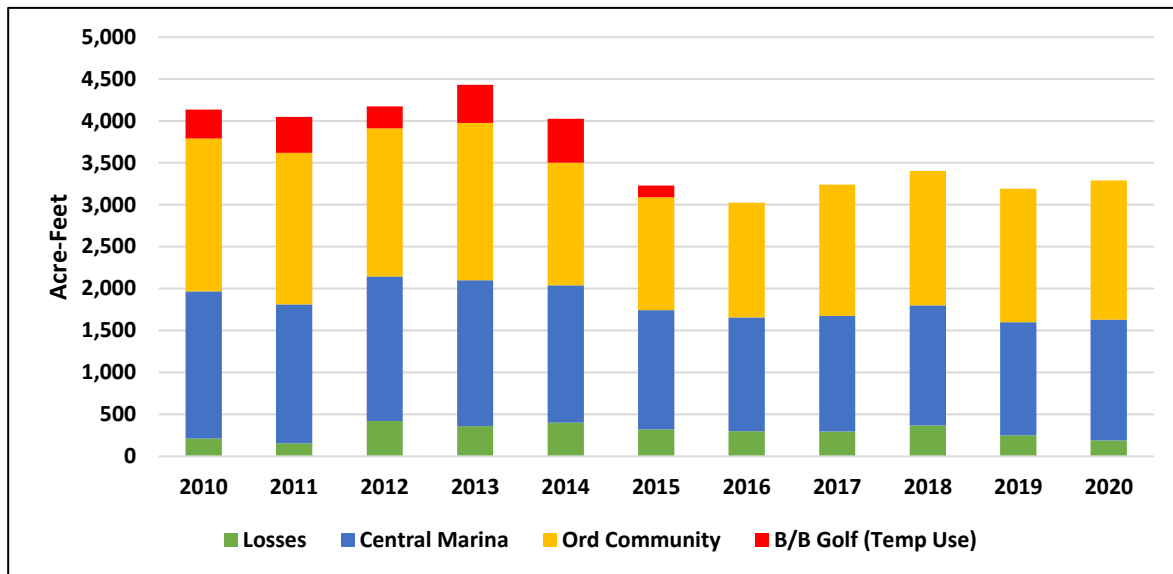

Future water demands are estimated based on in-fill and redevelopment projections provided by the jurisdictions served by MCWD. The projection methodology is discussed in Section 4 of this report, and the results are in Table 1.2, below. Due to the COVID-19 shelter-in-place orders in 2020, CSU Monterey Bay switched to remote learning and the campus was without students and faculty. For that reason, the projection uses the year 2018 demands as the baseline for CSUMB. Monterey Peninsula Unified School District also switched to remote learning, but those students continued to live within the District, so no adjustment was needed for those demands. Total water use is projected to more than double over the next 20-years.

¹ MCWD supplied water for irrigation of the Bayonet/Blackhorse Golf Course from 2010-2015 under an agreement with the City of Seaside. The golf course is now irrigated from City-owned wells.

Figure 1.3 Population and Per Capita Usage

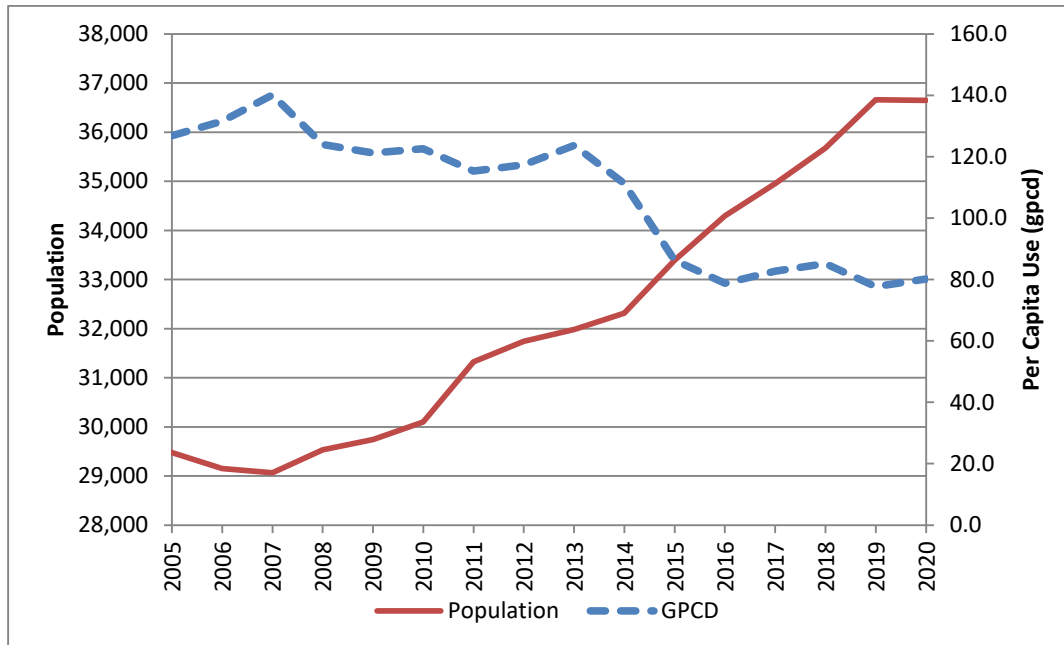

Table 1.2 Projected Water Demand by Jurisdiction (afy)

		Jurisdiction	2020	2025	2030	2035	2040	Notes
Ord	U.S. Army		409	461	471	471	471	1
	CSUMB		318	421	616	821	977	
	Del Rey Oaks		0	31	224	238	238	
	City of Monterey		0	0	130	130	130	
	County of Monterey		227	436	436	522	522	
	UCMBEST		1	116	335	377	408	
	City of Seaside		339	839	1,032	1,435	1,698	
	State Parks and Rec.		0	7	9	9	9	
	Marina Ord Comm.		446	1,125	1,638	1,757	1,809	
Marina	Armstrong Ranch		0	550	680	680	680	2
	CEMEX		0	0	0	0	0	
	Marina Central		1,438	1,656	1,874	2,081	2,284	
Subtotal - Ord			1,739	3,436	4,891	5,760	6,262	
Subtotal - Marina			1,438	2,207	2,553	2,761	2,964	
Assumed Line Loss			190	348	348	348	348	
Total			3,367	5,991	7,792	8,869	9,574	

1. CSUMB Campus closed for most of 2020 due to COVID-19 restrictions, so the 2018 campus usage is assumed as the baseline demand.
2. The CEMEX property is outside the Marina Urban Growth Boundary, which was extended to 2040.

1.4 Water Supplies

The District provides groundwater from the Monterey Subbasin of the Salinas Valley Groundwater Basin (SVGB). The SVGB covers approximately 620 square miles within Monterey County, and consists of several interconnected subbasins as listed in Table 1.3. Basin boundaries in the vicinity of MCWD are shown in Figure 1.4. The southern portion of the Ord Community overlies the Seaside Subbasin, which is an adjudicated aquifer, but none of the District's wells draw water from that source.

Table 1.3 Subbasins within the Salinas Valley Groundwater Basin

Basin Number	Designation	Area (acres)
3-4	Salinas Valley Groundwater Basin	
3-004.01	180/400 Foot Aquifer	88,700
3-004.02	East Side Aquifer	57,500
3-004.04	Forebay Aquifer	94,100
3-004.05	Upper Valley Aquifer	98,200
3-004.06	Paso Robles (Monterey & SLO Counties)	577,400
3-004.08	Seaside	14,500
3-004.09	Langley	17,600
3-004.10	Monterey	30,900
3-004.11	Atascadero (SLO County)	19,700

Marina Coast Water District and the former Fort Ord were separately annexed into Monterey County Zones 2/2A in 1996 and 1993, respectively. Under those agreements, MCWD agreed to limit their groundwater use to 3,020 afy, and Fort Ord agreed to a limit of 6,600 afy. Those limits are considered to be reliable yields. The 6,600 afy within the Ord Community was allocated to the various land use jurisdictions by the Fort Ord Reuse Authority so that they may plan for and entitle redevelopment projects. The land use jurisdictions sub-allocate the supply to projects and specific plans.

Under the Sustainable Groundwater Management Act of 2014, several groundwater sustainability agencies have been formed. The Salinas Valley Basin GSA covers all of the SVGB within Monterey County except the adjudicated Seaside Subbasin. The Seaside Subbasin is adjudicated and managed by the Seaside Basin Watermaster. The Marina Coast Water District GSA covers the portion of the Monterey and 180/400-Foot Aquifer Subbasins within their service area. The City of Marina GSA covers the portion of the 180/400-ft Aquifer within the City Limits but outside MCWD's service area. The Groundwater Sustainability Plan for the 180/400-Foot Aquifer Subbasin was published in January 2020, and the plan for the Monterey Subbasin is due for submission in 2022.

The District is currently constructing a recycled water distribution network and will begin delivering recycled water for urban landscape irrigation within the next few years. The producer of the recycled water is Monterey One Water (M1W), the regional wastewater treatment agency. M1W has two water recycling systems. The Salinas Valley Reclamation Plant, constructed in 1989, produces tertiary treated and disinfected recycled water used for crop irrigation within the Castroville Seawater Intrusion Project. The Advanced Water Purification Plant produces advanced treated water for Indirect Potable Reuse as part of the Pure Water Monterey Project. The advanced treated water is injected into the Seaside Groundwater Basin within the Ord Community. MCWD has metered turnouts along the transmission main for supplying advanced treated water to recycled water customers. The MCWD Phase 1 project is 600 afy, with a planned Phase 2 expansion to 1,427 afy.

The District constructed a pilot seawater desalination plant in 1996 to explore the feasibility of using shallow wells along the beach as a source of brackish water. The plant had a capacity of 300 afy, but is no longer in operation.

The District has sufficient groundwater plus contracted recycled water to meet the projected water demands of the next 20 years. As future water demands increase, the District will develop additional sources of water supply. The desalination of brackish groundwater has been studied in detail and remains a viable option. The District is currently studying the feasibility of Indirect Potable Reuse of advanced treated water from the Pure Water Monterey project.

1.5 Water Supply Reliability

The Salinas Valley Groundwater Basin has an estimated 19.8 million acre-feet of storage capacity, and groundwater levels have not declined significantly during drought cycles, so pumping within the agreed-upon limits is considered reliable. Recycled water originates as municipal wastewater from indoor water uses. Indoor water use sees less of a decline during drought restrictions than outdoor water use, so recycled supply is considered reliable as well. As a municipal water district with comparatively minimal pumping from the Salinas Valley Groundwater Basin (as compared with agriculture) and access to recycled municipal wastewater, the District is positioned to be less impacted should a significant reliability issue arise basin-wide.

In the event of a severe drought, natural disaster or major equipment failure, the District has adopted a Water Shortage Contingency Plan. The plan includes five action stages, with targeted restrictions on water use and clear reduction goals.

1.6 Conservation and Demand Management

The District has an active water conservation program to maintain their low per capita rates of water use. Restrictions on water waste are included in the District Code of Ordinances. Rebate programs are available for indoor and outdoor retrofits and replacements, and staff water conservation specialists are available to provide assistance to customers.

Section 2 - Plan Preparation

2.1 Background

The California Water Code, Division 6, Part 2.6, Section 10610 et. seq. (California Urban Water Management Planning Act) requires any municipal water supplier serving over 3,000 connections or 3,000 acre-feet of water per year (afy) to prepare an urban water management plan.

In adopting the Urban Water Management Planning Act, the state declared as policy that:

- a) The management of urban water demand and efficient use of water shall be actively pursued to protect both the people of the state and their water resources;
- b) The management of urban water demands and efficient use of urban water supplies shall be a guiding criterion in public decisions;
- c) Urban water suppliers shall be required to develop water management plans to actively pursue the efficient use of available supplies.

Through the Urban Water Management Planning Act, the state recognizes that water is a limited, though renewable, resource and that a long-term reliable supply of water is essential to protect the economy. It also recognizes that, while conservation and efficient use of water is a statewide concern, planning for this use is best done at the local level. Therefore each supplier is required to submit its plan to the State Department of Water Resources.

In preparing this 2020 Urban Water Management Plan (UWMP), the Marina Coast Water District (MCWD) reviewed its 2015 and 2010 UWMPs, schedule of water conservation best management practices actions and other supply development actions. Redevelopment of the former Fort Ord is continuing, with several new areas now covered by specific plans. The drought of record occurred in the last 5-year reporting period. The resulting increased water conservation awareness is still reflected in the current demands. These developments are reflected in the updated demand projection tables in this report.

2.2 Public Participation in Plan Development

MCWD has encouraged public participation in the development of this Urban Water Management Plan. Notice of plan development was placed on MCWD's website in May 2021. MCWD's Water Conservation Commission, a public advisory group which helps shape MCWD's conservation programs, was also notified.

On May 21, 2021, the draft UWMP was made available for public inspection at MCWD's offices and at local libraries. A public hearing was held for the plan on June 21, 2021 as noted in the Board resolution reproduced in Appendix A.

2.3 Agency Coordination

The Urban Water Management Planning Act modified under SB 1518, effective January 1, 2003, requires MCWD to notify affected land use jurisdictions of plan development and provide an opportunity to review the draft plan. Requests to participate in development of the plan, and copies of the draft plan were sent to each affected land use jurisdiction, the United States Army, which holds groundwater rights with MCWD's Ord Community Service Area, and the Monterey County Water Resources Agency (MCWRA). A notice of hearing for the draft UWMP was publicly published and sent to all public agencies MCWD serves including the cities of Marina, Monterey, Seaside, and Del Rey Oaks, the U.S. Army, the University of California Monterey Bay Educational, Science and Technology Center (UCMBEST), California State University – Monterey Bay (CSUMB), California State Parks Monterey District and Monterey County (see Table 2.1). Additionally, MCWD notified Monterey One Water (MIW) and the Monterey Peninsula Water Management District (MPWMD) of the plan's development and availability. Copies of these notices are in Appendix D.

MCWD will provide each of the public agencies listed above and the California State Library with a copy of the final plan. A final copy of the plan and appendices will be posted on the MCWD website: www.mcwd.org.

Table 2.1 Coordination with Appropriate Agencies

Coordinating Agencies	Was sent the initial projections	Provided feedback on initial projections	Was sent a notice of intention to adopt	Was sent a copy of the draft plan	Commented on the draft plan	Attended public hearing	Not involved/ No information
U.S. Army	X		X	X			
City of Marina	X		X	X			
City of Seaside	X		X	X			
City of Del Rey Oaks	X	X	X	X			
City of Monterey	X		X	X			
County of Monterey (RMA)	X		X	X			
CSUMB	X	X	X	X			
UCMBEST	X		X	X			
State Parks	X		X	X			
CalAm			X	X			
MCWRA			X	X			
MIW			X	X			
MPWMD			X	X			
General Public							

2.4 Plan Adoption

The 2020 Urban Water Management Plan was adopted by the Marina Coast Water District Board of Directors on June 21, 2021. A copy of the resolution approving the plan is included in Appendix A.

2.5 Plan Implementation

The District has adopted policies and procedures that facilitate implementation of the plan, with many of the actions already in progress:

- The District Code of Ordinances includes mandatory prohibitions on water waste, water shortage contingency actions, and enforcement provisions.
- MCWD prepares Water Supply Assessments and Written Verifications of Supply for proposed projects and provides them to the land use jurisdiction.
- MCWD reviews project plans compared to water allocations made by the land use jurisdictions. If a development's proposed connections exceed the allocated supply, MCWD contacts the affected jurisdiction to resolve the discrepancy before allowing the connections in question.
- MCWD monitors new developments to ensure the average water demand does not exceed the water allocation made by the land use jurisdiction, and works with project owners and the affected jurisdiction when water uses habitually exceeds the allocation.
- New water supply projects as reflected in this plan are in the approved Capital Improvements Program. MCWD has entered into formal agreements with Monterey One Water to implement the Pure Water Monterey Groundwater Replenishment Project (urban recycled water), as discussed in Section 5.
- MCWD has a full-time water conservation staff that provides customer assistance and manages the rebate programs discussed in Section 7.
- MCWD will be required to implement the Sustainable Groundwater Management Act discussed in Section 5.

2.6 Completed UWMP Checklist

As a verification of plan completeness, the DWR Urban Water Management Plan checklist has been completed and included at Appendix G.

Section 3 - System Description

3.1 District Location, History and Operations

The Marina Coast Water District is located on the coast of the Monterey Bay at the northwest end of the Salinas Valley (Figure 3.1). The District was formed in 1960 to provide potable water service to all residential, commercial, industrial, environmental, and fire protection uses in the unincorporated community of Marina. The original boundary was coincident with the Marina Fire District. In 1970, MCWD constructed a wastewater treatment plant and installed a wastewater collection system to serve the community. The City of Marina incorporated in 1975, but MCWD remained separate. In 1991, MCWD constructed a pilot recycled water system, providing tertiary treated wastewater for irrigation of public streetscapes and parks near the wastewater plant. This system operated only until 1992, when the wastewater collection system was connected to the regional wastewater system operated by the Monterey Regional Water Pollution Control Agency (recently renamed Monterey One Water). The Marina wastewater treatment plant was retired, and MCWD now provides wastewater collection services only, with treatment performed at the regional plant. In 1996, MCWD constructed a seawater desalination facility to explore the feasibility of extracting seawater through shallow wells along the beach. In 2019, MCWD formally annexed portions of the former Fort Ord.

The District's jurisdictional boundary² is 10.3 square miles, encompassing the City of Marina and the occupied portions of the former Fort Ord. The District has a 2.2 square-mile sphere of influence immediately north of its service area (see Figure 3.2). The District considers the remaining redevelopment parcels within the former Fort Ord as a future study area.

3.1.1 Central Marina Service Area

MCWD's Central Marina service area is the 3.2 square mile portion of City of Marina outside the former Fort Ord. Prior to the base closure in 1996, MCWD only served the City of Marina. When the base closed, MCWD began operating the potable water and wastewater collection systems on the former Fort Ord under agreements with the Army and the Fort Ord Reuse Authority. Two separate cost centers were established, Central Marina and the Ord Community (described below).

In 1996, MCWD entered into the Annexation Agreement and Groundwater Mitigation Framework for Marina Area Lands among MCWD, the City of Marina, the Monterey County Water Resources Agency (MCWRA), J.G. Armstrong family and RMC Lonestar (now CEMEX), to annex into Monterey County Zones of Benefit 2 and 2A. Under that agreement, MCWD may pump up to 3,020 AFY of Salinas Valley Groundwater for delivery to the Central Marina service area.

² Boundaries per the Local Area Formation Commission (LAFCO) of Monterey County

The agreement recognized the Armstrong property's right to use the groundwater underlying the property for irrigation but limited the property to 20 afy of potable water. The Armstrong property could withdraw an additional 150 afy of potable water when the property was annexed to Zones 2/2A and an additional 150 afy every two years thereafter, up to a total of 920 afy for potable purposes. Armstrong would be required to pay annexation fees to MCWRA in order to annex to Zones 2/2A. The Armstrong Ranch annexation to Zones 2/2A will be effective when LAFCO approves concurrent annexation to MCWD and the City of Marina.

The agreement limited the CEMEX property to its historic pumping rate of 500 afy of non-potable water. The CEMEX property could be annexed to MCWD upon payment of annexation fees to MCWRA. If CEMEX wanted to receive potable water, then CEMEX would be required to pay an additional annexation fee to MCWRA. The CEMEX annexation to Zones 2/2A will take effect when the CEMEX property is annexed to MCWD.

If and when these properties are annexed into MCWD, the District would have the right to pump and deliver those quantities of water to customers within those areas.

3.1.2 Ord Community Service Area

The District provides potable water delivery and wastewater conveyance services within the boundaries of the former Fort Ord Army Base, known as the Ord Community. The Ord Community lies to the southeast of the District's Central Marina service area (see Figure 3.2). The former Fort Ord encompasses a 44 square mile area, of which about 20 square miles is designated for redevelopment, with the balance being parks, open space and the Fort Ord National Monument.

In 1991 the former Army base was downsized and realigned pursuant to the Defense Base Closure and Realignment Act of 1990, with closure in 1994. Portions of the base were retained for use by the U.S. Army under the control of the Presidio of Monterey (Presidio Annex), with the balance being converted to civilian use under the guidance of the Fort Ord Reuse Authority (FORA), a public agency created for this purpose by the State of California. FORA existed from 1994 to 2020. Jurisdictions with lands within the former Fort Ord are:

- City of Del Rey Oaks
- City of Marina
- City of Monterey
- City of Seaside
- County of Monterey

The Base Reuse Plan also included provisions for three institutions of higher learning:

- California State University, Monterey Bay (CSUMB)

- University of California, Monterey Bay Environmental Science and Technology Center (UCMBEST)
- Monterey Peninsula College

FORA had the statutory authority to provide for public capital facilities, including but not limited to, water and wastewater facilities and capacity allocations on the former Fort Ord in support of the Base Reuse Plan. In May 1997, the FORA Board approved the preparation of a Public Benefit Conveyance (PBC) application to the federal government for transfer of the water distribution and wastewater collection systems to MCWD. In June 1997, the U.S. Army and MCWD signed a caretaker agreement authorizing MCWD to operate the water and wastewater collection systems. In February 1998, MCWD and FORA executed an agreement for water and wastewater facilities, providing for the ownership and operation of water and wastewater facilities acquired from the federal government for the benefit of the Ord Community service area. Title for these systems and the associated water and wastewater rights were transferred from the U.S. Army through FORA to MCWD in 2001, and the systems were subsequently interconnected. In 2007, MCWD combined the water system permits for the Central Marina and Ord Community service areas into a single California Department of Public Health Permit, No. 2710017. In 2019, MCWD completed the LAFCO process of annexing the occupied portions of the Ord Community into its service area.

Under the 1993 Agreement between the United States of America and the Monterey County Water Resources Agency concerning Annexation of Fort Ord into Zones 2 and 2A of the Monterey County Water Resources Agency, MCWRA allocated 6,600 afy of potable groundwater to the Army for use on Fort Ord. This amount is about equal to the peak historic water use on Fort Ord. Of this, MCWRA requires that not more than 5,200 afy may be pumped from the 180-Foot and 400-Foot aquifers, to reduce the risk of seawater intrusion. When the U.S. Army conveyed the water and wastewater rights and infrastructure on the former Fort Ord through FORA to MCWD, the Army retained a portion of the groundwater pumping rights and wastewater treatment capacity for the Presidio of Monterey Annex (also called the Ord Military Community). The U.S. Army contracted directly with MCWD to provide municipal water supply and wastewater collection services within the Ord Military Community³.

The Marina Coast Water District Board does not allocate water supply to projects, but instead advises customer land use jurisdictions as to the current and historic water use within their boundaries and the estimated remaining supply available for new developments. The City of Marina is a party to the 1996 Zone 2/2A Annexation and approves developments within the City.

³ Potable Water Utility Service for the Presidio of Monterey Annex, Contract DABT67-98-C-1001, dated 5/12/00, and Wastewater Collection Utility Service for the Presidio of Monterey Annex, Contract DABT67-98-C-1002, dated 5/12/00.

Within the Ord Community, the FORA Board managed the allocation of Salinas Valley groundwater supplies among the seven land use jurisdictions, and they, in turn, sub-allocate water supply to specific projects. Water allocations are discussed in a technical memorandum in Appendix E.

Figure 3.1 MCWD Vicinity Map

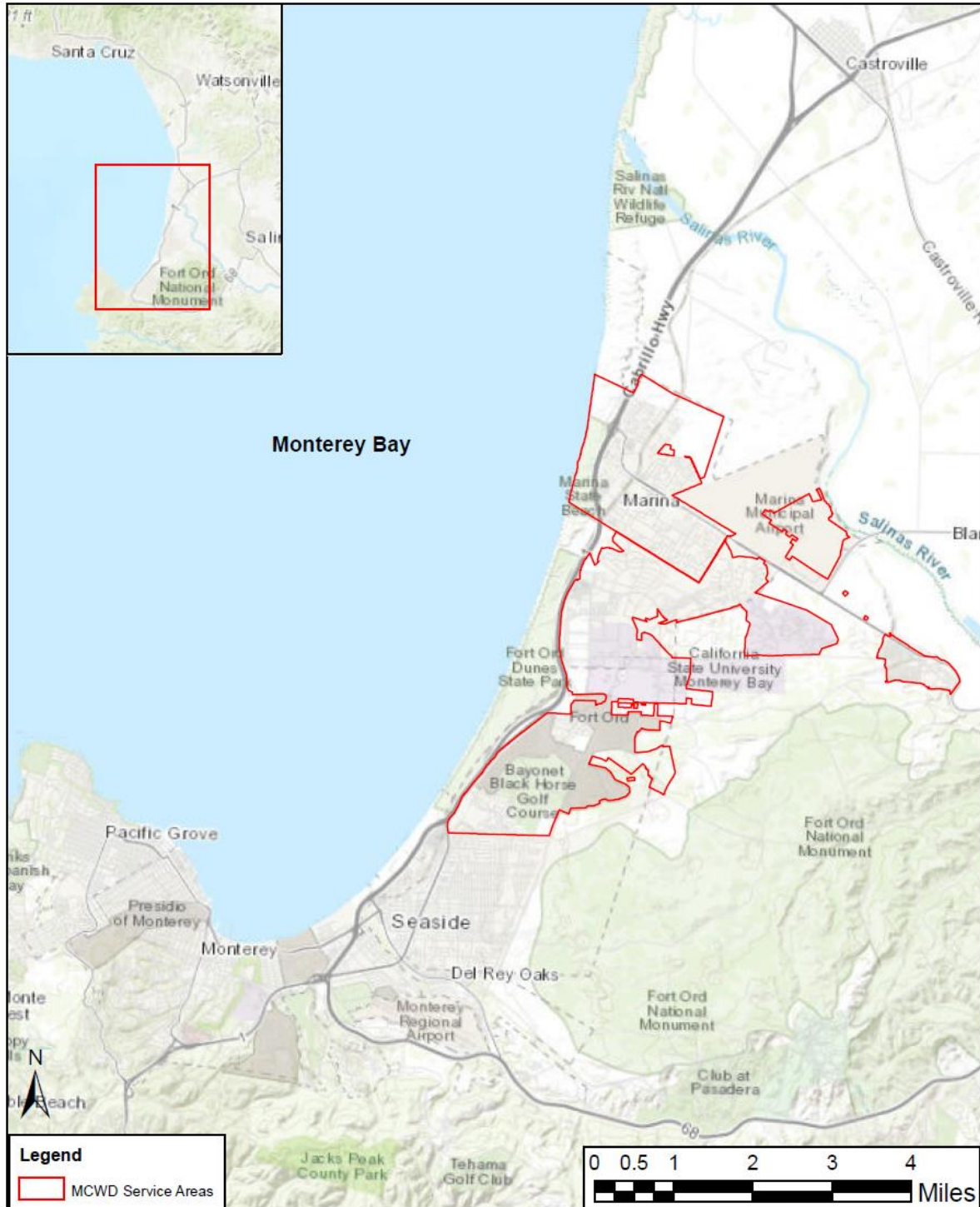
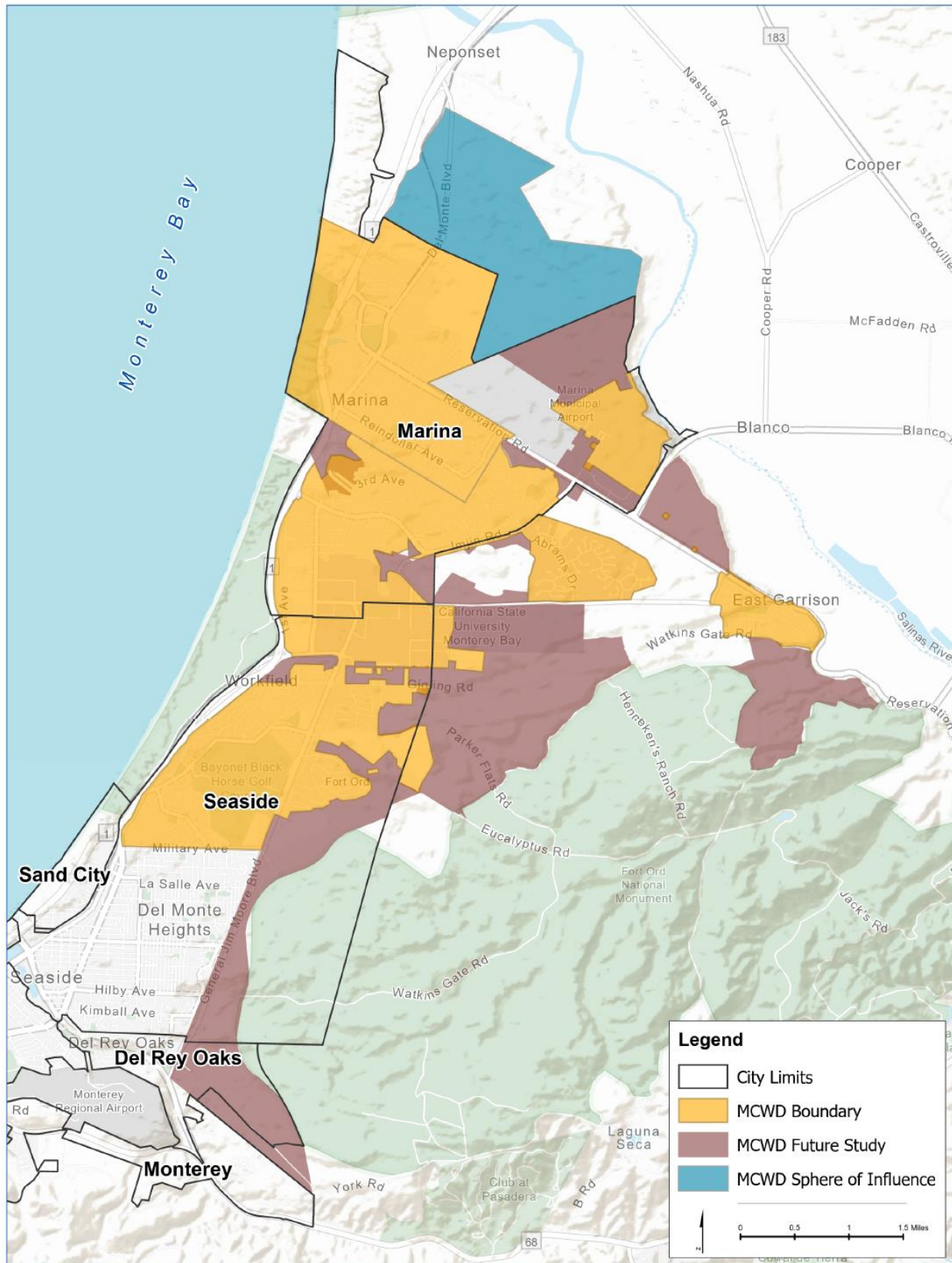

Figure 3.2 MCWD Service Areas



3.2 Climate

Marina has a cool summer-type Mediterranean climate with precipitation falling exclusively as rain, predominantly between October and May. The nearest official weather station is seven miles away in Monterey, California. Average climate data from this station from 1981-2020 is depicted in Figure 3.3.

Figure 3.3 Local Climate Averages

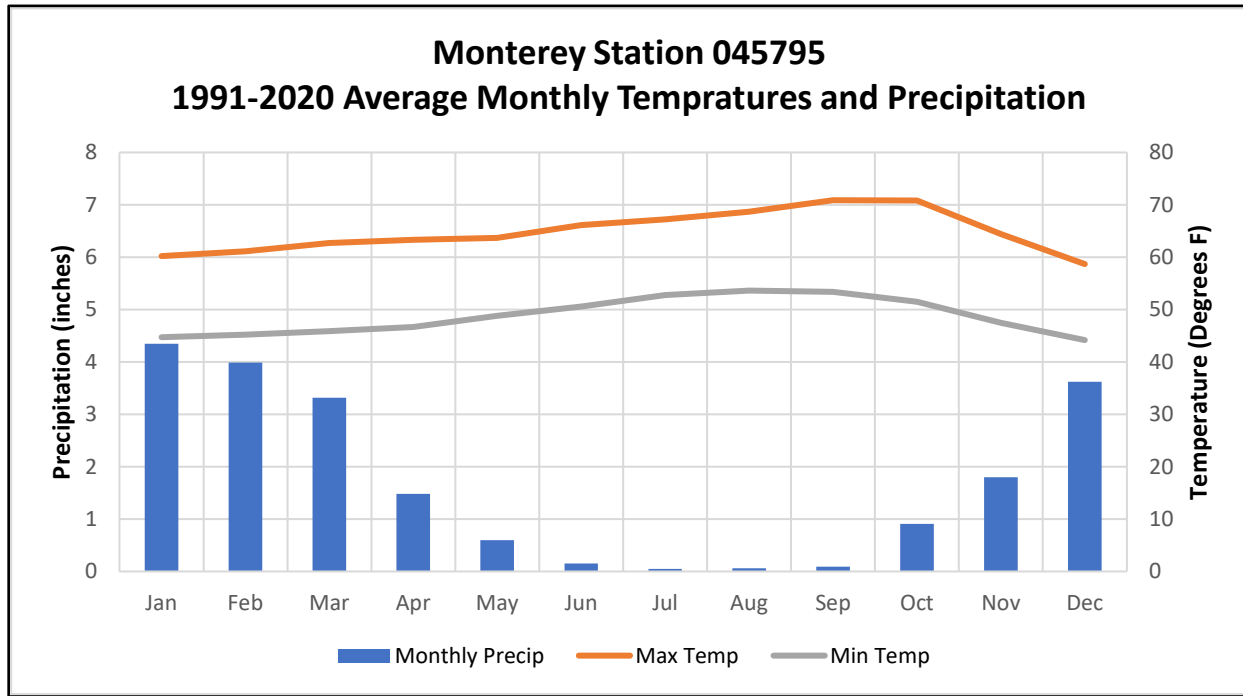

The moderating effect of the Pacific Ocean and its relatively cold water allows for mild summertime temperatures in Marina. This effect suppresses summertime irrigation demands for landscaping as compared to inland locations, especially when advection fog moves in from the Pacific Ocean, enveloping the immediate coast in response to heating inland. Unlike inland locations, summertime temperatures generally peak in September rather than July.

Peak summertime temperatures usually occur when high pressure is resident in the Great Basin (Santa Ana conditions), allowing for an offshore flow and compressional heating of the atmosphere.

Precipitation averages about 20 inches annually. Table 3.1 depicts monthly average evapotranspiration (ETo) at the nearest California Irrigation Management Information System (CIMIS) stations. Note that the ETo rate increases the more distant from the coast.

Table 3.1 Local Evapotranspiration Rates (inches)

City	CIMIS Station ID	Jan	Feb	Mar	Apr	May	Jun	Jul	Aug	Sep	Oct	Nov	Dec	Annual ETo
Castroville	19	1.6	1.9	3.1	4.2	4.8	4.8	4.1	3.6	3.2	2.7	1.8	1.5	37.2
Salinas North	116	1.6	1.9	3.1	4.1	4.5	4.9	4.4	4.2	3.6	2.9	1.8	1.5	38.5
Pacific Grove	193	1.8	2.4	3.4	4.2	4.4	4.3	3.9	3.3	3.5	3.0	2.0	1.7	37.8
Laguna Seca	229	1.7	2.2	3.3	4.3	4.6	5.3	5.3	4.8	4.0	3.2	1.9	1.5	42.0

3.3 Population

MCWD historically served only the City of Marina, which incorporated in 1975. In 1997, the District began providing service to the Ord Community under agreement with FORA. Table 3.2 depicts MCWD's growth from 1960 to 2010. Between 1920 and 1970, population increases for Marina were quite steady. From 1970 to 1980 the population nearly tripled. Growth rates moderated in the 1980s, with the population reaching a near-term peak in 1990. With the closure of Fort Ord as a military base in 1994, the City and MCWD experienced a decline in population (the on-base population was estimated at 31,000 in 1990).

Table 3.2 Historic Population

Service Area	1960	1970	1980	1990	2000	2010
City of Marina*	3,310	8,343	20,647	26,436	18,927	19,718
Ord Community**					14,886	10,762
Total	3,310	8,343	20,647	26,436	33,813	30,480

Source: U.S. Census Bureau

*City of Marina totals include the portion of the city within the Ord Community

**Ord Community totals exclude the City of Marina portion. Ord population shown only for period served by MCWD.

With redevelopment of the Fort Ord lands, population is steadily increasing. Population projections shown in Table 3.3. These projections include redevelopment of the Ord Community, including portions of the cities of Seaside, Del Rey Oaks, and Monterey, campuses for the University of California and California State University, and lands remaining under the jurisdiction of the County of Monterey within the boundaries of the former Fort Ord.

Table 3.3 Projected Population by Service Area

Year	2020	2025	2030	2035	2040
Central Marina*	14,297	19,520	21,647	23,279	24,881
Ord Community**	22,349	30,611	36,366	43,438	48,302
Population	36,646	50,131	58,012	66,717	73,183

*Central Marina totals exclude the portion of the city within the Ord Community.

**Ord Community totals include the City of Marina portion.

The above projections are based upon the existing population plus the anticipated occupancy of new residential development, as projected in Section 3. A more detailed discussion of the

methodology can be found in Appendices C and E. The projected population growth has consistently been conservatively high, based on in-fill and redevelopment projections. The 2015 UWMP projected the service area population would be 40,464 persons by 2020, which was 10% higher than the actual increase. New housing units were consistently added in the active development areas, but growth outside those areas did not occur at the projected pace.

3.4 Demographic Factors

Three industries have historically driven the local economy: agriculture in the Salinas Valley, tourism along the Pacific Coast and the Monterey Peninsula, and the military with bases at Fort Ord, the Presidio of Monterey and the Naval Postgraduate School. The closure of Fort Ord in 1994 greatly reduced the military contribution, but that has been replaced by higher education on the former Fort Ord. California State University – Monterey Bay is the largest campus within the Ord Community, which also contains the smaller campuses of Monterey College of Law and Monterey Peninsula College. The University of California Monterey Bay Education, Science and Technology Center is located at the Marina Municipal Airport.

Tourism and recreation are significant portions of MCWD’s current and future customer base. Central Marina currently has hotels and visitor-serving commercial sectors, as well as Marina State Beach. The Ord Community has Fort Ord Dunes State Park and approximately 24 square miles of open space managed by the Bureau of Land Management. BLM’s regional office is now located in Marina. The existing Bayonet and Blackhorse Golf Courses are being developed by the City of Seaside into a resort community.

Within the District’s service area there is a high percentage of residential use (92% of customer accounts, 68% of total water sales). This high percentage results in a low per capita water demand. Residents have historically worked on the former Fort Ord, as well in the nearby urban centers of Monterey, Salinas and the more distant San Jose/Silicon Valley; or in the agricultural industry of rural Monterey County. Employment on the former Fort Ord has not yet recovered to pre-closure levels.

As Central Marina and the Ord Community are redeveloped, a mix of commercial, office and light industrial uses are proposed, which will increase the average per capita water demand rate. High water-using industries are not anticipated due to the limited water supply available to the jurisdictions.

Section 4 - Water Demands

4.1 Current Water Use

Marina Coast Water District has two separate service areas: Central Marina, which encompasses the portion of the City of Marina outside the former Fort Ord, and the Ord Community. All water service connections in the Central Marina area are metered. Fort Ord did not have individual service meters while it was an active military base, so water meters were installed as housing areas were renovated. The last area was metered in 2019, so the District now has no flat rate accounts. Water use by customer type for calendar year 2015 is shown in Table 4.1, and year 2020 is shown in Table 4.2.

Table 4.1 Water Deliveries in 2015

Water use sectors	Central Marina		Ord Community		Ord Non-metered		Total
	# Cust.	Ac-Ft	# Cust.	Ac-Ft	# Cust.	Ac-Ft	Ac-Ft
Single family	3,280	741.0	1,334	227.1			968.1
Multi-family	261	399.2	1,636	505.6	735	205.8	1,110.6
Commercial	232	231.7	75	95.3			327.0
Industrial	0	0.0	2	0.2			0.2
Institutional/governmental	25	41.7	136	114.2			155.9
Landscape	18	242.9	139	389.3			632.3
Agriculture	0	NA	0	NA			0
Other	0	NA	0	NA			0
Total	3,816	1,656.6	3,322	1,331.7	735	205.8	3,194.1

Table 4.2 Water Deliveries in 2020

Water Use Sectors	Central Marina		Ord Community		Total	
	# Cust.	Ac-Ft	# Cust.	Ac-Ft	# Cust.	Ac-Ft
Single family	3,403	680.2	2,681	499.1	6,084	1,179.3
Multi-family	230	397.3	2,350	540.9	2,580	938.2
Commercial	250	205.5	94	119.6	344	325.0
Industrial	0	0.0	4	0.7	4	0.7
Institutional/governmental	23	39.3	138	99.1	161	138.3
Landscape	97	113.0	172	410.0	269	523.0
Agriculture	0	NA	0	NA	0	NA
Other	0	NA	0	NA	0	NA
Total	4,003	1,435.2	5,439	1,669.4	9,442	3,104.6

MCWD provided water for irrigation of Bayonet/Blackhorse Golf Courses in Seaside from 2010 to 2015. Prior to this, the City of Seaside provided irrigation supply from wells within the Seaside Groundwater Basin, which was the source of supply for this demand at the time the former Fort Ord closed. In 2015, the City transitioned back to using Seaside Groundwater Basin wells for the golf courses, which is reflected in the reduced usage for landscape irrigation.

4.2 Projected Water Demands

4.2.1 Central Marina Service Area Demands

In October 2000, the City of Marina adopted a comprehensive General Plan laying out future land use over a 20-year planning horizon to the year 2020. The General Plan was amended several times, most recently in 2010, and the housing element was updated in 2015. In the adopted General Plan the City's population (anticipated to expand into current spheres of influence) was projected to be between 38,000 and 40,000 by 2020⁴. This included increases in both Central Marina and the City's portion of the Ord Community. The economic recession from December 2007 to June 2009 delayed much of this redevelopment by five to ten years. The Marina General Plan estimates water consumption for the City will average 7,720 afy based upon the projected land uses and population. It also includes portions of the Ord Community that are either within the City limits or within its adopted and proposed spheres of influence. These areas include portions of the UCMBEST Center and CSUMB, which have separate specific allocations of water under the FORA Reuse Plan.

Even with the resumption of development in recent years, the City's average per-capita water demand is low and has been trending downward due to aggressive water conservation programs. Per capita demands will continue to be affected by conservation efforts, future land use changes as well as increases in density of housing use (persons/unit). Marina has had a historically low job-to-housing ratio, due in part to the fact that the City has been a bedroom community to the former Fort Ord, Monterey and San Jose areas. The General Plan build-out will allow for greater balance in jobs-to-housing. This trend will tend to increase the average per capita water consumption, as more commercial and industrial activity will occur relative to population. If housing density increases, this would have an opposite influence, reducing per capita demand.

The City is working to adopt a Downtown Vitalization Specific Plan, for which a water supply assessment (WAS) was prepared in 2020. Under this plan, the City projects the addition of up to 1,385,200 square-feet of commercial space and up to 2,900 new multi-family dwelling units, targeting a pedestrian friendly downtown. As part of the WSA analysis, the City Planning staff updated the in-fill potential analysis for the balance of the City. Although the specific plan has not yet been formally adopted, both the WAS projection and the revised City-wide infill projection are reflected in this update to the UWMP.

There are two significant undeveloped areas north of Central Marina: Armstrong Ranch and the CEMEX (formerly RMC Lonestar) Property. MCWD currently serves minor domestic uses on the Armstrong Ranch, and in the future, MCWD will serve municipal and industrial demands as they may occur on these properties. Current agricultural demands are met via private wells.

⁴ This population includes an estimated 3,400 residents of the existing Fredericks-Schoonover Park, a housing area in Marina's sphere of influence.

Marina's General Plan accounts for growth within portions of the Armstrong Ranch, which was annexed into the City in 2007. The Marina Station Development Project on the Armstrong Ranch comprises 1,464 residential units and about 856,000 square feet of retail, office and light industrial space. Development density will be constrained by the available water supply as provided under the 1996 Annexation Agreement and Groundwater Mitigation Framework for Marina Area Lands, annexing the Armstrong Ranch lands to the MCWRA Zones 2 and 2A. According to that agreement, the Salinas Basin groundwater allocation for the Armstrong Ranch is 920 afy. This is further discussed in Section 5.

Similarly, the CEMEX Property, for which there are no near-term development plans, has a groundwater allocation under the annexation agreement of 500 afy, corresponding to the estimated use on the property. If CEMEX were to be developed for visitor-serving or recreation uses, it could only occur after the year 2040 pursuant to the City of Marina Urban Growth Boundary Initiative. Planned development in these areas is included in the subtotals discussed in Section 4.2.4.

4.2.2 Ord Community Service Area Demands

The Fort Ord Reuse Authority developed the Draft Fort Ord Reuse Plan in 1996, and released the associated Draft Environmental Impact Report (DEIR). This plan and DEIR assessed the impacts of planned reuse on the environment, including demand for utility services. The DEIR noted that at full build out, some 40 to 60 years in the future, water demands for Ord Community lands would be 18,262 afy, or 11,662 afy in excess of current potable water supply now available to the lands under groundwater allocations from the Salinas Valley groundwater basin. Recognizing that plans did not exist to accommodate this excess demand, it was concluded in the DEIR that the Reuse Plan had a significant unavoidable environmental impact. It was also stated that the 7,000 acre-foot water use on the former Fort Ord lands (6,600 Salinas Basin, 400 Seaside Basin) provided sufficient supplies to allow for expected redevelopment through 2015.

In adopting a Final EIR, Reuse Plan and Master Resolution governing redevelopment of former Fort Ord lands to civilian uses, FORA agreed to constrain redevelopment on former Fort Ord lands by limiting the number of new residential housing units to 6,000 until the Reuse Plan is reassessed, and additional water supplies identified. FORA further recognized that the supply of Salinas Basin groundwater available to serve redevelopment, or reuse, projects is limited by a 1993 agreement with the MCWRA. Under that 1993 Agreement, 6,600 afy of Salinas Basin groundwater is available for use on Ord Community lands. Since the closure of Fort Ord, the 6,600 afy was divided between the U.S. Army and the Ord Community, with FORA managing the sub-allocation of this Salinas Basin groundwater supply to its member land-use jurisdictions to support redevelopment projects within the Ord Community. FORA managed the groundwater sub-allocations through a Development and Resource Management Plan until the agency ceased to exist in July 2020.

One of the mitigation measures in the Final EIR, Reuse Plan and Master is the development of 2,400 afy of additional water supply for the Ord Community, which will allow development beyond the initial 6,000 dwelling units. FORA worked with MCWD to develop this supply under the Regional Urban Water Augmentation Project, which is discussed in Section 5.4.1.

As part of this UWMP update, MCWD surveyed land use jurisdictions responsible for development decisions within the Ord Community Service area for their development plans through the year 2040. Where used in this plan, individual responses from the Cities of Marina, Seaside, Del Rey Oaks and Monterey, the County of Monterey, CSUMB, UCMBEST, and the U.S. Army are detailed in Appendix C. These responses were correlated with the City of Marina General Plan Housing Element, City of Seaside General Plan Housing Element, the City of Seaside's Implementation Plan, 2007-2012, Seaside-Fort Ord Redevelopment Project Area, and the Monterey County General Plan.

4.2.3 Demand Projection Methodology

The primary method for developing future water demands in this Plan is through consolidating information from approved Specific Plans and the associated Water Supply Assessments, when available. Water supply assessments have been prepared per the requirements of SB 610 for the developments listed in Table 4.3. These documents contain detailed estimates of water demand for residential, commercial and irrigation use type, and are used as the basis of water supply allocation by the land use jurisdiction to the projects.

Table 4.3 Water Supply Assessments Used to Update the UWMP⁵

Development	Jurisdiction	Year Prepared
Cypress Knolls	Marina	2006
Dunes on Monterey Bay (University Villages)	Marina	2007
Sea Haven (Marina Heights)	Marina	2003
Marina Station	Marina	2006
Marina Downtown Vitalization Specific Plan	Marina	2020
Marina Airport Business Park/UC MBEST	Marina/UC MBEST	2020
Resort at Del Rey Oaks	Del Rey Oaks	2007
Campus Town	Seaside	2018
Seaside Main Gate (Amended Specific Plan)	Seaside	2018
Monterey Downs / Veterans Cemetery	Seaside/County	2012
East Garrison	Monterey County	2004

Within the last five years, several water supply assessments were prepared for projects within the cities of Marina and Seaside. In Marina, the City is considering two specific plans, one for vitalization of the City's urban core in Central Marina, and one for development of a business

⁵ The WSAs did not conclude that there was existing water supply available for every project. Shortfalls were identified in the WSAs for Cypress Knolls, Campus Town, Monterey Downs and the Marina Airport.

park at the Marina Airport in the Ord Community. In Seaside, the City amended the specific plan for the Main Gate Development and adopted a specific plan for the Campus Town project, both in the Ord Community. Also in the City of Seaside, the effort on the Monterey Downs specific plan ceased when the developer opted not to extend their agreement with the City. That project included residential development, a horse park/stables and the California Central Coast Veterans Cemetery. Of those elements, only the Veterans Cemetery was carried forward into the 2020 UWMP.

Several of the listed WSAs are over ten years old and have not progressed into approved projects. In Marina, the Cypress Knolls project has not moved forward, but the WSA estimate is still included because it is consistent with the general plan zoning for that area. In Del Rey Oaks, the resort developer did not complete the EIR process, but the City was looking for another developer to assume the project. In this update to the UWMP, the golf course portion of the resort project was removed from the 20-year projection, but a reduced number of housing units and commercial development is included per the final FORA development projection.

Where water supply assessments do not exist, land-use development forecasts were used. California State University Monterey Bay projections are from the 2017 Draft Comprehensive Master Plan. The U.S. Army – Ord Military Community projections are carried forward from the 2015 UWMP. The projections provided by the other land use jurisdictions for areas outside specific plan areas reflect planning estimates based on the approved General Plans. The anticipated additional land uses in various categories were tabulated by year, and demands were calculated by applying water use factors for those uses. These factors (see Table 4.4) are general in nature and ultimate actual use can vary significantly, especially among the broad categories of commercial and industrial uses.

On-campus uses specific to CSUMB were developed for the 2015 UWMP using ten years of meter data compiled by the campus facilities staff. Campus staff has since fine-tuned these factors and provided them to the District for use in the Water System Master Plan and this UWMP. The following demand factors were used in the demand projection for CSUMB:

- Dormitory: 0.036 AFY/bed (based on 0.031 AFY/bed for in-dorm use and 0.005 AFY/student for dining commons use)
- Academic Building: 0.000021 AFY/sq-ft for indoor demand
- Landscaping: 0.000051 AFY/SF for academic buildings and dormitories
- Dining additions: 0.00012 AFY/SF for the food service portion of designated facilities.

Table 4.4 Water Demand Factors Applied in the UWMP

Land Use	Units	Multiplier
SF Residential (< 5 units / acre)	dwelling unit	0.5
SF Residential (5-8 units / acre)	dwelling unit	0.33
Residential (8-15 units / acre)	dwelling unit	0.25
Multifamily (> 15 units / acre)	dwelling unit	0.25
Hotel, Motel and Timeshares	unit	0.11
Retail	square-feet	0.00021
Restaurant*	square-feet	0.00145
Office / R&D	square-feet	0.000135
Other Commercial	square-feet	0.0003
Light Industrial	square-feet	0.00015
Governmental	square-feet	0.0003
Institutional	square-feet	0.0003
Schools (K-12)*	square-feet	0.0003
Higher Education**	square-feet	0.000072
Landscape (non-turf)	acre	2.1
Landscape (turf)	acre	2.5

* typical per seat factor converted to square-feet

** includes both indoor and landscape use

MCWD modified its District Code in August 2005 to require additional conservation measures in the construction of new development and remodeling. These new requirements include incorporation of hot water recirculation systems and high efficiency clothes washers for residential units, and zero-use urinals for non-residential construction. These residential requirements are expected to achieve the State water conservation goal of an average indoor per capita consumption rate of 55 gallons per person per day.

It has been observed that during the development process and in the preparation of water supply assessments and written verifications of supply, more sophisticated forecasts are made by disaggregating indoor and outdoor uses when the proposed land use data is sufficient to support such analyses. These assessments generally result in lower projected water demands than the general methods used in this Plan. In a long-term forecast such as provided here, the precise types of uses and plot plans that will be constructed and maintained over the long term cannot be precisely known. As development proceeds, market forces will dictate the specific land uses within non-residential zones and refined plans for residential uses will allow for more detailed consumption projections. The Urban Water Management Planning Act recognizes this fundamental nature of demand forecasting in requiring updated Urban Water Management Plans every five years. In the case of MCWD, where development in the next twenty years is expected

to dramatically change the nature of the community and more than double its population and water demands, these periodic updates will be critical to MCWD's ability to plan for future demands as they are identified.

4.2.4 Summary of Demand Projections

Table 4.5 summarizes the projected demands from all currently expected development and population growth through 2040. Included for comparison are the existing allocations of groundwater supply by jurisdiction, which are explained in Section 4. The projected 20-year water demands in this Urban Water Management Plan are lower than the 20-year projection in the 2015 UWMP (approximately 10,000 afy in this UWMP vs. 11,000 afy in the 2015 UWMP). This reduction is due to several factors, discussed below.

Table 4.5 Water Demand by Jurisdiction (afy)

	Jurisdiction	2020	2025	2030	2035	2040	Notes	Allocation
Ord	U.S. Army	409	461	471	471	471		1,577
	CSUMB	318	421	616	821	977	1	1,035
	Del Rey Oaks	0	31	224	238	238		243
	City of Monterey	0	0	130	130	130		65
	County of Monterey	227	436	436	522	522		720
	UCMBEST	1	116	335	377	408		230
	City of Seaside	339	839	1,032	1,435	1,698		1,012
	State Parks and Rec.	0	7	9	9	9		45
	Marina Ord Comm.	446	1,125	1,638	1,757	1,809		1,325
	Assumed Line Loss	190	348	348	348	348		348
Marina	Armstrong Ranch	0	550	680	680	680		920
	CEMEX	0	0	0	0	0	2	500
	Marina Central	1,438	1,656	1,874	2,081	2,284		3,020
Subtotal - Ord		1,929	3,784	5,239	6,108	6,610		6,600
Subtotal - Marina		1,438	2,207	2,553	2,761	2,964		4,440
Total		3,367	5,991	7,792	8,869	9,574		11,040

1. CSUMB Campus closed for most of 2020 due to COVID-19 restrictions, so the 2018 campus usage is assumed as the baseline demand.
2. The CEMEX property is outside the Marina Urban Growth Boundary, which was extended through the year 2040.

As mentioned earlier in this section, the proposed golf course in Del Rey Oaks was removed, which reduced the City's projected demand by 200 afy. The proposed Monterey Downs development was removed from the City of Seaside, which had a projected demand of 850 afy. Within the Army housing projection, the demand factor for the proposed child development center was revised to be consistent with the existing child development center, which reduced the projected demand for that facility by 160 afy. Also within the Army housing projection, all of

the units are metered as of 2019, so the 2020 water use is accurate, compared to previous years where a portion was based on a flat rate estimate. The District assumed a usage of 0.33 afy/dwelling unit under the flat rate, while actual use is closer to 0.24 afy/dwelling unit.

As discussed in Section 3.1.2, the 6,600 AFY of existing groundwater pumping rights for the Ord Community have been allocated among the land use jurisdictions. Table 4.5 shows that the current groundwater allocation for Central Marina is sufficient to meet projected demands through 2040. The City of Marina's Downtown Vitalization Specific Plan is projected for build-out by the year 2050, and is not projected to increase the Central Marina water demand above the available groundwater supply. The Ord Community is projected to fully use its Salinas Valley groundwater allocation, but individual jurisdictions may exceed their allocations as early as 2030. This is discussed in detail in Section 4, Water Supply.

4.3 Projected Water Demand by Sector

Table 4.6 shows the projected water consumption by use sector in the period 2020-2040.

Table 4.6 Water Demand by Sector (afy)

Water use sectors	2020	2025	2030	2035	2040
Single family	1,180	2,214	2,650	2,923	3,173
Multi-family	966	1,401	1,676	2,064	2,332
Commercial	325	1,009	1,764	2,095	2,235
Industrial	1	68	254	263	272
Institutional/Governmental	171	220	258	281	292
Landscape	533	706	809	862	888
Agriculture	0	0	0	0	0
Other (provision for loss)	190	374	380	380	380
Total	3,367	5,991	7,792	8,869	9,574

Note: provision for loss includes both Central Marina and the Ord Community

4.3.1 Lower Income Housing Demands

The Water Code requires water suppliers to document water demand projections for lower income single family and multi-family housing within their UWMPs. Lower income is defined in Section 50079.5 of the Health and Safety Code as less than 50% of the area median household income.

The housing elements of the general and specific plans for the land use jurisdictions served by MCWD all include Affordable Housing requirements. Affordable Housing, as required in the California Redevelopment Law and specified within Monterey County, includes four income levels: very low, low, moderate and workforce. Only the first two levels, very low income and low income, must be reported separately in the UWMP. The following discussion explains how the current and projected lower income housing water demands were estimated.

The City of Marina has seven existing publicly assisted affordable housing projects. Within the Central Marina Service Area, the City has 240 low and very low income multi-family units. Within the Ord Community, the City has 677 affordable housing units, of which 236 are low and very low income. All of the existing units are multi-family duplex, four-plex or apartments. The City requires new residential development of twenty or more units to include a minimum of 20% affordable housing. Within that 20%, 6% must be very low income, 8% must be low income and 6% must be moderate income. Based on approved specific plans, lower income projections for the City include 15 units at the downtown Monterey-Salinas Transit Station, 93 apartments in Cypress Knolls, 53 duplexes in the Dunes on Monterey Bay, and 177 apartments within Marina Station. The City projects 64 low-income units within infill development parcels, and up to 964 low-income units within the Downtown Vitalization Specific Plan area.

The City of Seaside currently has 51 affordable multi-family units in the Ord Community, of which 41 are designated for lower income households. Within the current housing projection, we assume the City will require 20% of all new units to be affordable, with 14% being low-income units.

Monterey County requires 20% of all residential development or redevelopment to be affordable housing. Within that 20%, 6% must be very low income, 8% must be low income and 6% must be moderate income. Workforce housing requirements are then assigned on a project by project basis. Within the East Garrison Development, 196 low and very low income housing units are identified in the project specific plan, greatly exceeding the minimum requirement. 65 of those units have been constructed.

UCMBEST is expected to develop 290 multi-family and 240 single family units within the Ord Community, in unincorporated areas within the Marina Sphere of Influence. For these projects, we have assumed that 14% of the units will be restricted for lower incomes, as required by both the County and City.

The City of Del Rey Oaks has not yet developed its portion of the Ord Community. In the current UWMP, the housing projection is 275 new units. We have assumed that 14% of those (38 units) will be low-income unit, consistent with the County requirements.

Two institutional entities within the Ord Community, CSUMB and the U.S. Army, provide housing within the Ord Community for their students and employees. Because the assignment of this housing is governed by different rules than the California Redevelopment Law, we have assumed it to be workforce housing (and not low income) for the purpose of this report.

For projects with an approved Water Supply Assessment (WSA), the projected water demands were based upon the demand rates for the applicable type of housing unit in the WSA. For existing housing units and all other projected development, demands were estimated using the multi-family residential demand factor of 0.25 acre-feet per year. The time-phasing of lower

income housing was assumed to match that of the larger development. The results are shown in Table 4.7.

Table 4.7 Lower Income Housing Demands (afy)

	Jurisdiction	2020*	2025	2030	2035	2040
Ord	U.S. Army		0	0	0	0
	CSUMB		0	0	0	0
	Del Rey Oaks		0	11	13	13
	City of Monterey	16	16	16	16	16
	County of Monterey		39	39	39	39
	UCMBEST	10	10	27	32	37
	City of Seaside		28	33	99	131
	State Parks and Rec.		0	0	0	0
	Marina Ord Comm.	59	226	367	508	648
Marina	Armstrong Ranch		39	44	44	44
	CEMEX		0	0	0	0
	Marina Central	60	105	151	196	240
Subtotal - Ord		86	321	494	707	884
Subtotal - Marina		60	144	195	240	285
Total		146	465	689	948	1,169

*Existing demands estimated at 0.25 AFY/EDU

4.4 Water Conservation Baseline and Targets

The Water Conservation Act of 2009 (SB X7-7) requires each retail urban water supplier to establish baseline daily per capita water demand and water conservation targets, as outlined in California's 20x2020 Water Conservation Plan. The plan established a statewide goal of reducing average per capita water demand by twenty percent by the year 2020. The State estimated the average statewide demand for 2005 at 192 gallons per capita day (gpcd), with a statewide conservation target of 154 gpcd in 2020. An interim statewide target of 173 gpcd (ten percent reduction) by the year 2015 was also established. In the 20x2020 Plan, regional baselines and targets were also established.

The Marina Coast Water District is in the Central Coast Hydrologic Region. The regional baseline water demand was estimated to be 154 gpcd, the lowest in the state. The regional conservation targets are 139 gpcd by the year 2015, and 123 gpcd by the year 2020.

The Department of Water Resources (DWR) published detailed methodologies as to how baselines and targets are to be calculated. Baseline per capita water demands are calculated as a ten-year average water consumption rate for a period ending not earlier than December 31, 2004 and not later than December 31, 2010. This is calculated as gross annual water demand divided by average annual population. Water suppliers may choose any consecutive ten-year period

within the allowable window, corresponding to calendar years, fiscal years or other standard reporting intervals. Once established, the baseline demand must be used for compliance reporting in 2015 and 2020, and the same reporting year (calendar, fiscal, etc.) must be used. If the system-wide average water demand is 100 gpcd or less, the water supplier is not required to achieve additional conservation savings.

Historic water demand for MCWD is shown in Table 4.8. Annual population values were estimated using estimates from the California Department of Finance, as detailed in Appendix E. As can be seen, MCWD's average water demand has been at or below the regional 2020 target of 123 gpcd since 2009. The 10-year averages ending in 2004 and 2005 were not considered in selecting a baseline period, due to the large population changes in the mid-1990's when Fort Ord closed. Of the remaining periods, MCWD selected the period ending December 31, 2008, for calculating the baseline water demand, which is 135.3 gpcd. This period includes years with and without construction activity in the Ord Community, and is considered a more representative median than the lower value in later years.

Per Section 10608.20 of the Water Code, there are four methodologies available for calculating compliance targets, as listed below. A more detailed discussion of the methods and analysis are were provided in Appendix E of the District's 2010 UWMP.

- Method 1: Eighty percent of the water supplier's baseline per capita water use.
- Method 2: Per capita daily water use estimated using the sum of performance standards applied to indoor residential use; landscaped area water use; and commercial, industrial, and institutional uses.
- Method 3: Ninety-five percent of the applicable state hydrologic region target as stated in the State's April 30, 2009, draft 20x2020 Water Conservation Plan.
- Method 4: Estimated water savings by using conservation Best Management Practices (BMP) as prescribed by the California Urban Water Conservation Council (CUWCC). This method is similar to Method 2, but requires more detailed information on current water uses.

Table 4.8 Per Capita Water Demands

Year	Central Marina			Ord Community			System-Wide		
	Marina Pop.	Annual Water Use (MG)	Daily Per Capita (gals)	Ord Pop.	Annual Water Use (MG)	Daily Per Capita (gals)	Daily Per Capita (gals)	10-year Average (gpcd)	5-year Average (gpcd)
1995	16,685	657.6	108	5,000	913.0	500	198		
1996	16,465	690.5	115	7,796	811.4	285	170		
1997	16,586	699.6	116	10,593	838.7	217	155		
1998	17,128	606.1	97	11,119	679.7	167	125		
1999	17,331	730.4	115	11,327	780.6	189	144		
2000	17,574	749.4	117	11,563	772.7	183	143		
2001	17,715	744.6	115	11,701	726.0	170	137		
2002	17,781	751.5	116	11,867	696.2	161	134		
2003	17,805	712.1	110	11,808	698.7	162	131		
2004	17,876	737.0	113	11,757	789.5	184	141	147.8	
2005	17,672	715.1	111	11,805	649.6	151	127	140.6	
2006	17,509	582.1	91	11,645	817.5	192	132	136.8	
2007	17,493	528.6	83	11,572	958.3	227	140	135.3	134.0
2008	17,706	597.4	92	11,827	739.3	171	124	135.3	132.7
2009	17,852	639.2	98	11,891	676.5	156	121	132.9	128.7
2010	18,057	568.1	86	12,043	778.5	177	123	130.9	127.9

* Annual population values based upon CA Dept. of Finance estimates.

Water suppliers may select any of the four methods to calculate compliance water demand targets. They must also calculate the maximum allowable target, and select the lower of the two. The alternate maximum method consists of calculating a five-year average water consumption rate for a period ending not earlier than December 31, 2007 and not later than December 31, 2010. The 2020 conservation target must be less than or equal to 95% of the 5-year base daily per capita usage. MCWD selected the period ending December 31, 2008, for its 5-year baseline period, as reflected in Table 4.9.

Water demands within the District are already significantly below the state and regional averages due to aggressive water conservation practices. Therefore, MCWD has elected to use Method 3, which is a goal of 5% below the regional target. As seen in Table 4.9, the maximum allowable target is greater than the Method 3 target, so the Method 3 target may be used. The interim (2015) target is the average of the 10-year baseline and the 2020 target.

Table 4.9 District Baseline and Targets

Description	Year	Amount
Baseline Water Demand	2008	135 gpcd
Maximum Target (95% of 5-year baseline)	2020	126 gpcd
Method 3 Target (95% of Regional Target)	2020	117 gpcd
Interim Target	2015	125 gpcd

The District's actual 2020 water use was 3,291 AFY, and the population is estimated at 36,646 persons, resulting in an average 80.2 gpcd. This is well below the required conservation target and was achieved by implementing District-wide conservation practices, but is also partially due to the CSUMB campus switching to remote learning due to the COVID-19 pandemic restrictions. It is anticipated that water use will increase in future years, but that the average usage rate will remain below the conservation target due to the significant number of water conservation retrofits achieved in the past decade.

4.4.1 Plan for Meeting Urban Conservation Targets

Table 4.10 shows the total projected water demands for the District, the projected population and the resulting per capita water demands. The average demand per person increases in the future due to the projected non-residential development. Population projections are based upon the projected housing developments and the associated persons per unit in the respective specific plans. Where specific plans do not exist, the average persons per unit for the City or census tract were used. Population tables are included in Appendix C.

Table 4.10 Projected Per Capita Water Demands

	2020	2025	2030	2035	2040
Projected Demand (AFY)	3,367	5,991	7,792	8,869	9,574
Projected Recycled Water (AFY)*	0	600	953	1,140	1,270
Net Potable Demand (AFY)	3,367	5,391	6,839	7,729	8,304
Projected Population	36,646	50,131	58,012	66,717	73,183
Projected demand per person (gpcd)	82.0	96.0	105.2	103.4	101.3
Water Use Targets (gpcd)	117	117	117	117	117
Projected Target Exceedance (gpcd)	None	None	None	None	None

*Based on RUWAP Recycled Water Project Schedule

To reduce per capita demands below the compliance targets, the District has three strategies, in addition to the on-going water conservation efforts:

- First, MCWD is implementing an urban recycled water project for landscape irrigation.
- Second, the design standards for new construction exceed the State's plumbing code requirements for water conserving features.

- Third, the phased redevelopment of the Ord Community will include the replacement of a significant amount of water distribution system that is over 50-years old. These replacements should reduce system water losses but are not reflected in this table.

As seen in the bottom line of Table 4.10, the delivery of recycled water for landscape irrigation is sufficient to offset the projected addition of non-residential development. The District’s water production and per capita demand rate have steadily declined over the past fifteen years due to water conservation retrofits, consumer education and replacement of existing housing stock. Per capita use is stabilizing around 80 gpcd, as shown in Figure 4.1 and Table 4.11.

Figure 4.1 Population and Per Capita Usage

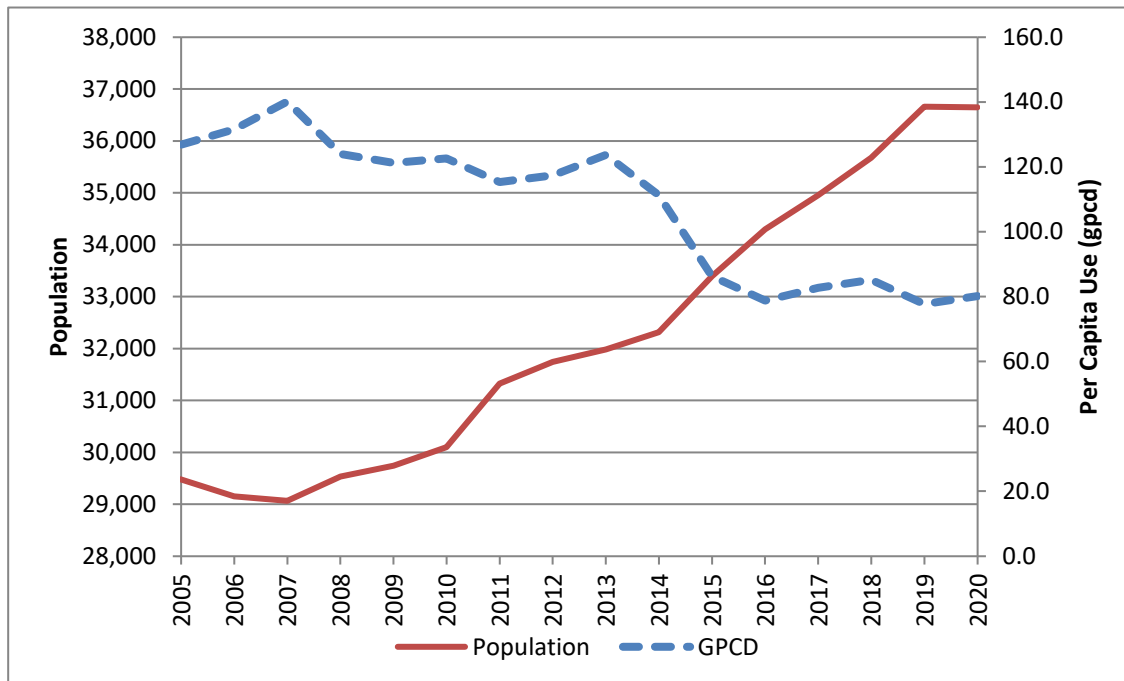

Table 4.11 Per Capita Water Demand, 2011-2020

Year	Population	Water Use (AF)	Average gpcd
2011	31,326	4,047	115.3
2012	31,742	4,174	117.4
2013	31,984	4,431	123.7
2014	32,313	4,026	111.2
2015	33,394	3,228	86.3
2016	34,297	3,025	78.7
2017	34,957	3,239	82.7
2018	35,673	3,405	85.2
2019	36,661	3,190	77.7
2020	36,646	3,291	80.2

The use of recycled water to serve non-potable demands is a conservation measure recognized in the 20x2020 State Conservation Plan. As detailed in Section 4, MCWD included recycled water in the Regional Urban Water Augmentation Program, completed the project design and CEQA documents in 2007. On April 8, 2016, MCWD and M1W entered into the Pure Water Delivery and Supply Project Agreement, wherein the District will receive up to 1,427 AFY of advanced treated recycled water from the Pure Water Monterey Project. As shown in Table 4.10, the project is expected to provide 600 afy by 2025, and increase to 1,359 afy by 2030.

MCWD has adopted design guidelines and standards that exceed the state plumbing code requirements for water conserving fixtures, codified in Section 3.36 of the District Ordinances. New residential development is required to include high-efficiency toilets, hot-water recirculation systems, and when provided, clothes washers must meet high efficiency standards. Non-residential development must include waterless urinals and HET or dual-flush toilets. All landscapes over 2,500 square-feet are separately metered and must meet the requirements of the State's model water-efficient landscape ordinance.

Section 5 - Water Supplies

5.1 Water Sources and Water Rights

The sole source of potable water supply for the Marina Coast Water District is the Salinas Valley Groundwater Basin, described in detail in Section 5.2. Both Central Marina and the Ord Community Service areas have relied upon this source of supply since the areas were initially developed. The District owns and operates its production wells, and does not purchase wholesale potable water supply. The District is currently constructing a recycled water distribution system, and will begin purchasing recycled water in the near future.

As discussed in Section 3, under the 1993 and 1996 Annexation Agreements for Zones 2 and 2A, MCWRA granted groundwater allocations of 6,600 AFY to the Army and 3,020 AFY to MCWD. The 1996 Annexation Agreement recognized the Armstrong Ranch's right to use groundwater for overlying irrigation uses and allocated 20 AFY of potable water. The agreement reserved an additional 900 AFY of potable water (920 AFY total) for the Armstrong Ranch subject to annexation to Zones 2/2A and to MCWD and the City of Marina. The agreement also recognized and limited the CEMEX property to its historic use of 500 AFY of non-potable water use. Zone 2 was formed as a benefit and assessment zone to finance the construction and operation of Lake Nacimiento, and Zone 2A was formed as a benefit and assessment zone to finance the construction and operation of Lake San Antonio.

The 1996 Annexation Agreement established "a contractual process for the exercise of regulatory authority by the MCWRA under Water Code App. Section 52-22, and the MCWD under Water Code section 31048."⁶ The purpose of the 1996 Annexation Agreement was to "establish a groundwater mitigation framework for the lands to be annexed, and will provide money from the Marina area for the MCWRA's Basin Management Plan and for Zones 2 and 2A, for management protection of the groundwater resource in the Salinas Valley Groundwater Basin and to reduce seawater intrusion."⁷

MCWRA's Backstop: Under the 1993 and 1996 Annexation Agreements, MCWRA has "allocated groundwater pumping rights" to Fort Ord and to the Marina Area Lands. Under the Annexation Agreements, MCWRA has agreed to backstop those groundwater allocations in the event that the actual available groundwater is not physically or legally available (e.g., because of a Salinas Valley Groundwater Basin adjudication).

Section 4.g of the 1993 Annexation Agreement states:

- g. Should future litigation, regulation or other unforeseen action diminish the

⁶ MCWRA Negative Declaration re: Annexation of Marina Area Lands to Zones 2/2A, dated February 21, 1996, at p. 4.

⁷ Purpose section, Attachment B-1 to Initial Study for Marina Lands Annexation.

total water supply available to the MCWRA, the MCWRA agrees that it will consult with the Fort Ord/POM Annex Commander. Also, in such an event, the MCWRA agrees to exercise its powers in a manner such that Fort Ord/POM Annex/RC shall be no more severely affected in a proportional sense than the other members of the Zone.

Section 8.1 of the 1996 Annexation Agreement states:

8.1. Equal treatment by MCWRA and MCWD. If future litigation, regulation or other unforeseen action diminishes the total water supply available to MCWRA, MCWRA agrees that it will exercise its powers so that MCWD, Armstrong and Lonestar shall be no **more** severely affected in a proportional sense than other lawful users of water from the Zones, based on the right before the imposition of any uniform and generally applicable restrictions as described in paragraph 8.2 to use at least the quantities of water from the Basin described in paragraphs 5.1., 6.9., and 7.2. MCWRA shall not at any time seek to impose greater restrictions on water use from the Basin by MCWD, Armstrong or Lonestar than are imposed on users either supplying water for use or using water within the city limits of the City of Salinas. MCWD, Armstrong and Lonestar will comply with any basin-wide or area-wide water allocation plans established by the MCWRA which include MCWD, Armstrong and Lonestar, and which do not impose on use of water on the lands described in Exhibits "B", "C", and "D" restrictions greater than are imposed on users either supplying water for use or using water within the City of Salinas, and which satisfy the requirements of paragraph 5.2 of this Agreement and Framework.

Table 5.1 provides the recent groundwater production for the Central Marina and Ord Community service areas. Note that well capacity is not included in the table. MCWD has redundant well pumping capacity to accommodate maintenance shut-downs during peak days.

Table 5.1 Groundwater Production (acre-feet)

Year	Central Marina	Ord Community	Total (ac-ft)
2011	1,698	2,348	4,047
2012	1,814	2,360	4,174
2013	1,467	2,964	4,431
2014	1,619	2,407	4,026
2015	1,420	1,808	3,228
2016	1,303	1,722	3,025
2017	1,587	1,651	3,239
2018	1,744	1,661	3,405
2019	1,425	1,764	3,189
2020	1,216	2,075	3,291

The three water production wells in the Central Marina service area and one in the Ord Community are in the Deep Aquifer, as described in Section 5.2.1. The other four wells in the

Ord Community service area are in the 400-foot Aquifer. Until recently, MCWD was the only significant user of the Deep Aquifer. Over the last decade, six new agricultural wells were added in this formation and reported extractions from the Deep Aquifer have more than doubled. A portion of that use increased occurs only when irrigation supply from the Castroville Seawater Intrusion and Salinas River Diversion Projects cannot meet the daily agricultural demands.

Energy use by the District is provided in Appendix I.

5.2 Groundwater

5.2.1 Salinas Valley Groundwater Basin

Potable water for MCWD's Marina and Ord Community service areas comes from wells developed in the Salinas Valley Groundwater Basin.⁸ This groundwater basin underlies the Salinas Valley from San Luis Obispo County to the coast of Monterey Bay. DWR Bulletin 118: California's Groundwater places Marina and Fort Ord in the 180/400 Ft, Monterey and Seaside Sub-basins (see Figure 5.1 and Figure 5.2) of the Salinas Valley Groundwater Basin. The Bulletin 118 subbasins within the Salinas Valley Groundwater Basin (SVGB) are listed in Table 5.2.

Table 5.2 DWR Subbasins within the Salinas Valley Groundwater Basin

DWR Basin /Subbasin Number	DWR Designation	Area (acres)	DWR Priority Ranking	Sustainability Plan Status
3-4	Salinas Valley Groundwater Basin			
3-004.01	180/400 Foot Aquifer	88,700	High/Critical*	Submitted 2020
3-004.02	East Side Aquifer	57,500	High	Due in 2022
3-004.04	Forebay Aquifer	94,100	Medium	Due in 2022
3-004.05	Upper Valley Aquifer	98,200	Medium	Due in 2022
3-004.06	Paso Robles (Monterey & SLO Counties)	577,400	High/Critical*	Submitted 2020
3-004.08	Seaside	14,500	Medium	Adjudicated
3-004.09	Langley	17,600	Medium	Due in 2022
3-004.10	Monterey	30,900	Medium	Due in 2022
3-004.11	Atascadero (SLO County)	19,700	Medium	Due in 2022

*Designated as a Critically Over-drafted Subbasin by DWR January 2016

⁸ See Figure 5.2 for well locations.

Figure 5.1 Monterey County Groundwater Basins and Sub-Basins⁹

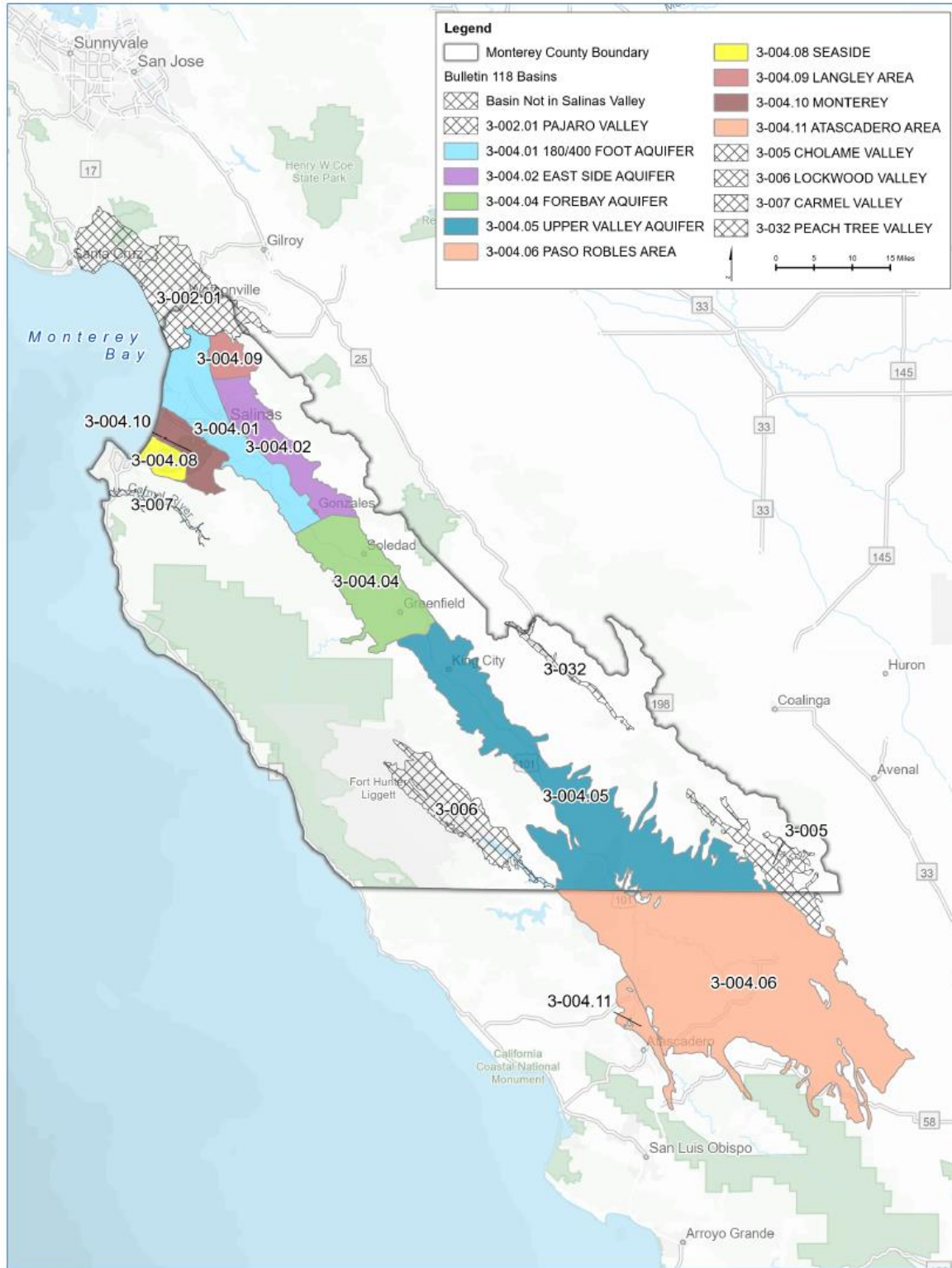

⁹ Figure from Monterey County Water Resources Agency, 2019.

Figure 5.2 Sub-Basin Boundaries and MCWD Wells and Service Areas

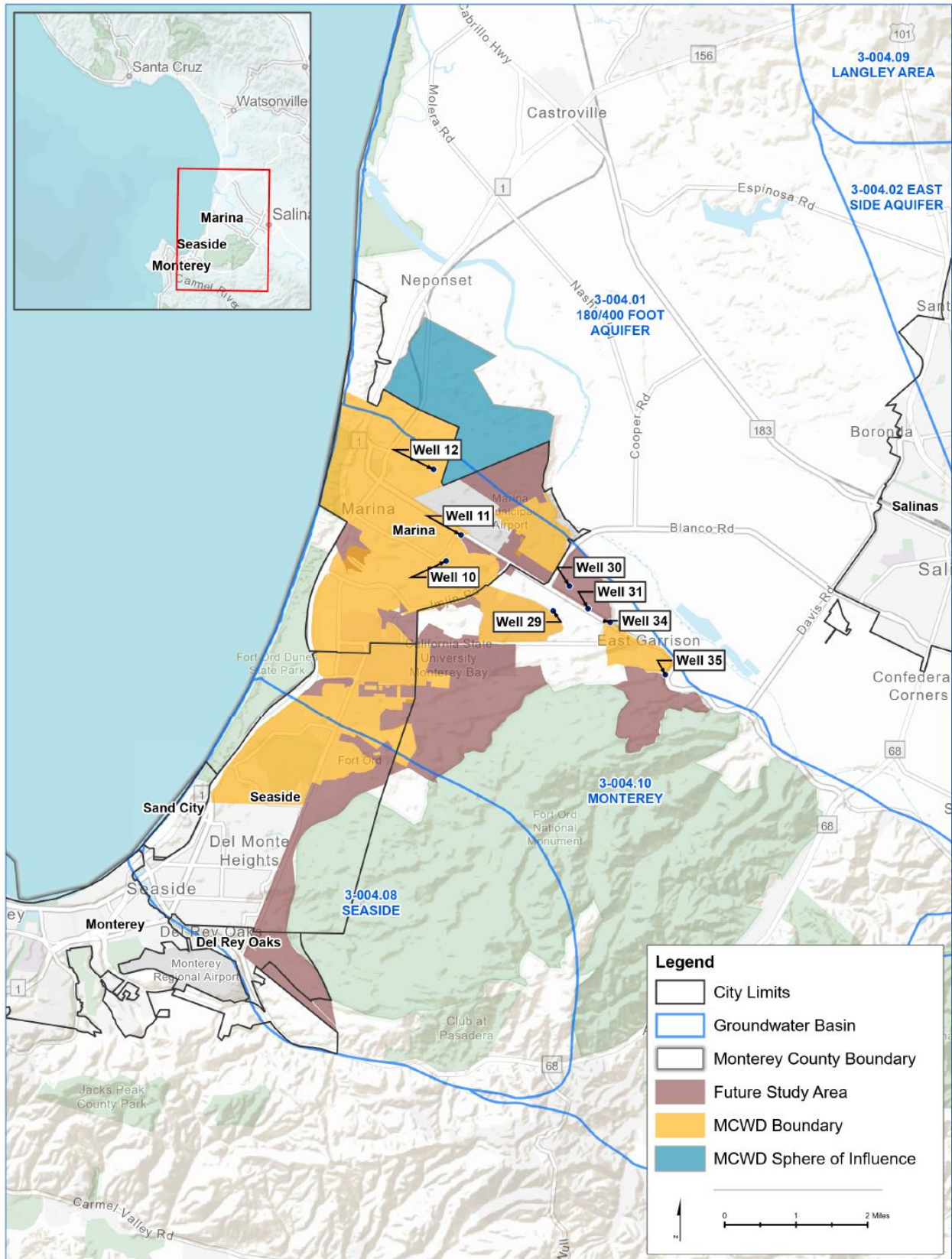

The 2016 Update to DWR Bulletin 118 redefined the basin boundaries in the vicinity of MCWD. The Seaside Subbasin previously extended north into Marina but was revised to reflect the adjudicated basin boundary. The new Monterey Sub-basin includes the northern portion of the Seaside sub-basin plus the previous Corral de Tierra Sub-Basin. The Monterey Subbasin generally includes lands west of the Salinas River of higher elevation than the 180/400 Foot Aquifer Subbasin. The Monterey Subbasin has an additional water bearing strata above the 180-ft Aquifer, designated as the “A” or Dune Sand Aquifer. The Monterey Sub-basin is connected to the 180/400 Foot Aquifer Subbasin, but is separate from the Seaside Subbasin due to a ridge in the water-bearing formations. The southern portion of the Seaside Subbasin was formally adjudicated in 2006 and is managed by the Seaside Basin Watermaster.

MCWRA reports and documents generally use Zone 2/2A designated subareas, Pressure, East Side, Forebay and Upper Valley (Figure 5.3), which do not conform with the DWR Bulletin 118 Subbasins. The Pressure Subarea combines three DWR Bulletin 118 Subbasins: the 180/400 Foot Aquifer Subbasin, the Monterey Subbasin and a portion of the Seaside Subbasin. The southwest corner of the Pressure Subarea boundary is coincident with the Zone 2/2A annexation boundary for Fort Ord. To avoid confusion over subbasin and subarea designations and references, this Plan shall use the DWR Bulletin 118 subbasin designations. Portions of MCWD’s Ord Community service area extends into the Seaside Subbasin, but all of the District’s current wells are located within the Monterey Subbasin.

The 180/400 Foot Aquifer Subbasin is delineated vertically into three distinct aquifer zones, consisting of aerially extensive, largely horizontally continuous, deposits of sand and gravel that exist at various depths below ground surface in the subarea. These three aquifers are commonly referred to as the 180-Foot, 400-Foot and Deep aquifers. The 180-Foot and 400-Foot aquifers derive their names from the average depth below the valley floor at which the water bearing sand and gravel deposits are encountered. The Deep Aquifer consists of an aggregation of all sand and gravel deposits that exist below the 400-Foot Aquifer including aquifers in the Aromas Sand, the Paso Robles Formation and the Purisima Formation, not all of which are hydraulically connected. The shallowest alluvial aquifer in the basin is the A-Aquifer, which is perched on top of the Salinas Valley Aquitard, above the 180-Foot aquifer, and overlies most of the 180/400 Foot Aquifer Subbasin. Toward the coast, the A-Aquifer is comprised of mostly dune sand deposits, which are largely unconfined in the coastal area of the basin.

The 180-Foot Aquifer extends from Monterey Bay to Chualar beneath the Salinas Valley and westward from the valley under northern Ord Community and Central Marina. South of Chualar and in the Forebay area, the distinction between the 180-Foot and 400-Foot aquifers becomes less defined as the aquitards that effectively separate them become increasingly discontinuous.

Figure 5.3 MCWRA-designated Subareas of the Salinas Valley Groundwater Basin¹⁰



¹⁰ Source: MCWRA 2009 Groundwater Summary Report

The 400-Foot Aquifer is comprised of geological materials assigned to older alluvium deposits and Aromas Sand. The aquifer system is present beneath the northern Salinas Valley and also extends westward beneath the northern portions of the former Fort Ord and Central Marina. In the Forebay area, the 400-Foot Aquifer is hydraulically connected with the 180-Foot Aquifer resulting in both aquifer zones receiving recharge from the Salinas River through the overlying recent alluvial deposits.

The Deep Aquifer System consists of two geologic formations – the Paso Robles and the underlying Purisima Formations. These formations are aerially extensive, and not only underlie the Salinas Basin but continue outside the basin to the north and south. The lowermost unit (Purisima Formation) extends to the north outcropping in Soquel and Santa Cruz, and to the south where it grades into the Santa Margarita Formation, an important aquifer in the Seaside Basin. Although slightly arbitrary in definition, the Deep Aquifer is commonly believed to begin at depths of approximately 600 feet below sea level and extend to depths of up to 2,000 feet or more in some locations. Non-water bearing Monterey Shale that constitutes the bottom of the Salinas Groundwater Basin underlies the Deep Aquifer system.

Studies by the United States Geological Survey indicate that Deep Aquifer water in the vicinity of Marina is not of recent origin. Uncorrected Carbon 14 dating of water from a test well in the vicinity of Marina's Deep Aquifer wells indicates the water is between 22,000 and 31,000 years old. The ancient nature of this water raises the possibility that recharge to this aquifer may be insufficient to sustain current pumping, but monitoring well data at the Marina Airport¹¹ indicates the aquifer is subject to seasonal variations similar to the upper aquifers. Recent stratigraphic analyses have indicated that these aquifers are connected hydraulically at certain locations with the 180-foot and 400-foot aquifers, which may be recharging the Deep Aquifer.¹²

Because the overlying clay layers isolate the aquifer systems in the 180/400 Foot Aquifer Subbasin from potential surface water recharge, most importantly the Salinas River, the primary mechanism for recharge is from lateral flow from the adjacent subareas. This means that most recharge for the aquifer systems in the 180/400 Foot Aquifer Subbasin comes from lateral flow from the Monterey, Eastside or Forebay Subbasins. Additionally, the deeper aquifers are believed to be recharged in whole or in part by water that has moved through the overlying aquifers (i.e., flow from the shallow aquifer partially recharges the 180-Foot Aquifer, which then partially recharges the 400-Foot Aquifer that in turn partially recharges the Deep Aquifer). Most of the recharge for the 180/400 Foot Aquifer Subbasin derives from the Forebay Subbasin due to natural recharge from the Salinas River, which is augmented by MCWRA's active management of Nacimiento and San Antonio reservoir releases to maximize river recharge.

¹¹ MCWD Well 34 Basis of Design Report, Martin B. Feeney, PG, September 2009

¹² Deep Aquifer Investigation Study, WRIME, 2003.

In a balanced condition, Salinas Basin groundwater would move through the basin and into the Monterey Bay through sea floor freshwater aquifer outcrop areas. As a result of basin-wide pumping, water levels in the 180/400 Foot Aquifer and East Side Subbasins have declined over time, contributing to a decrease in the amount of groundwater moving toward and into Monterey Bay and developing a trough or depression in groundwater levels in the East Side sub-basin (see Figure 5.4). The basin currently experiences a landward groundwater gradient of causing seawater intrusion, where the seawater has contaminated coastal aquifers and wells. While historic groundwater pumping throughout the basin contributes to the overdraft, only the basin's coastal areas adjacent or near to the Bay suffer from seawater intrusion. Seawater intrusion is further discussed in Section 5.2.5. The other basin subareas – Forebay and Upper Valley – tend to recharge rapidly and recover historic groundwater levels each year. The result has been a reversal of the seaward gradient.

The Salinas Valley Groundwater Basin has been in an overdraft condition with seawater intruding at an estimated rate of 11,000 to 18,000 afy into the 180/400 Foot Aquifer Subbasin.¹³ MCWD's groundwater withdrawals are about 3,300 afy, or less than 1.0 percent of total annual basin withdrawals of about 475,300 afy¹⁴. Other than MCWD, only a small number of wells tap the deep aquifer, some of which also draw from the 400-Foot aquifer. Prior to receiving recycled water for crop irrigation, some agricultural lands in the Castroville area pumped water from the Deep Aquifer. These agricultural wells are currently used to meet supplemental needs during peak summer demands periods and are also part of the monitoring network overseen by MCWRA. Delivering recycled water to replace groundwater pumping has contributed to a recovery in groundwater levels in this area. The addition of surface water from the Salinas Valley Water Project has further reduced groundwater pumping for irrigation.

¹³ Salinas Valley Water Project Engineer's Report, RMC, 2003.

¹⁴ MCWRA, Groundwater Extraction Report, WY 2018

5.2.2 Sustainable Groundwater Management Act

On September 16, 2014, Governor Edmund G. Brown Jr. signed three bills into law, which are collectively known as the Sustainable Groundwater Management Act (SGMA), effective January 1, 2015. SGMA created a framework for sustainable, local groundwater management for the first time in California history. SGMA's core principles¹⁶ are:

- Groundwater should be locally and collaboratively managed to address unique basin conditions and challenges.
- Groundwater should be managed sustainably.
- The state's role should complement and support the goal of local sustainable groundwater management.
- Water rights should be protected.

Previously adjudicated basins, including the Seaside Groundwater Basin, are exempt from the SGMA except for annual reports required to be filed with DWR.¹⁷ As discussed previously, the Seaside Subbasin boundaries have been adjusted to coincide with the adjudicated boundary. The Seaside Basin Watermaster will continue to manage that Basin without any state oversight under SGMA. MCWD will continue to work and cooperate with the Watermaster.

The GSA is the primary local agency responsible for achieving SGMA's groundwater sustainability goals. Several groundwater sustainability agencies (GSA) have been formed to manage the Salinas Groundwater Basin (see Figure 5.5). The Salinas Valley Basin Groundwater Sustainability Agency (SVBGSA) covers all of the SVGB within Monterey County except the adjudicated Seaside Subbasin. The Marina Coast Water District GSA covers the District's service area, overlapping the SVBGSA. Where portions of GSAs overlap, they are referred to as non-exclusive. The City of Marina and County of Monterey have both formed GSAs to cover the CEMEX property, which is inside the City Limits but outside MCWD's service area and sphere of influence. The City of Marina and County of Monterey GSAs have the same boundary, which is not allowed under the SGMA. That conflict has not yet been resolved.

¹⁶ CalEPA, DWR, SWRCB, et al., Groundwater Legislation Implementation Fact Sheet, December 4, 2014.

¹⁷ Water Code Section 10720.8(a)(21) and (f).

Figure 5.5 Groundwater Sustainability Agencies

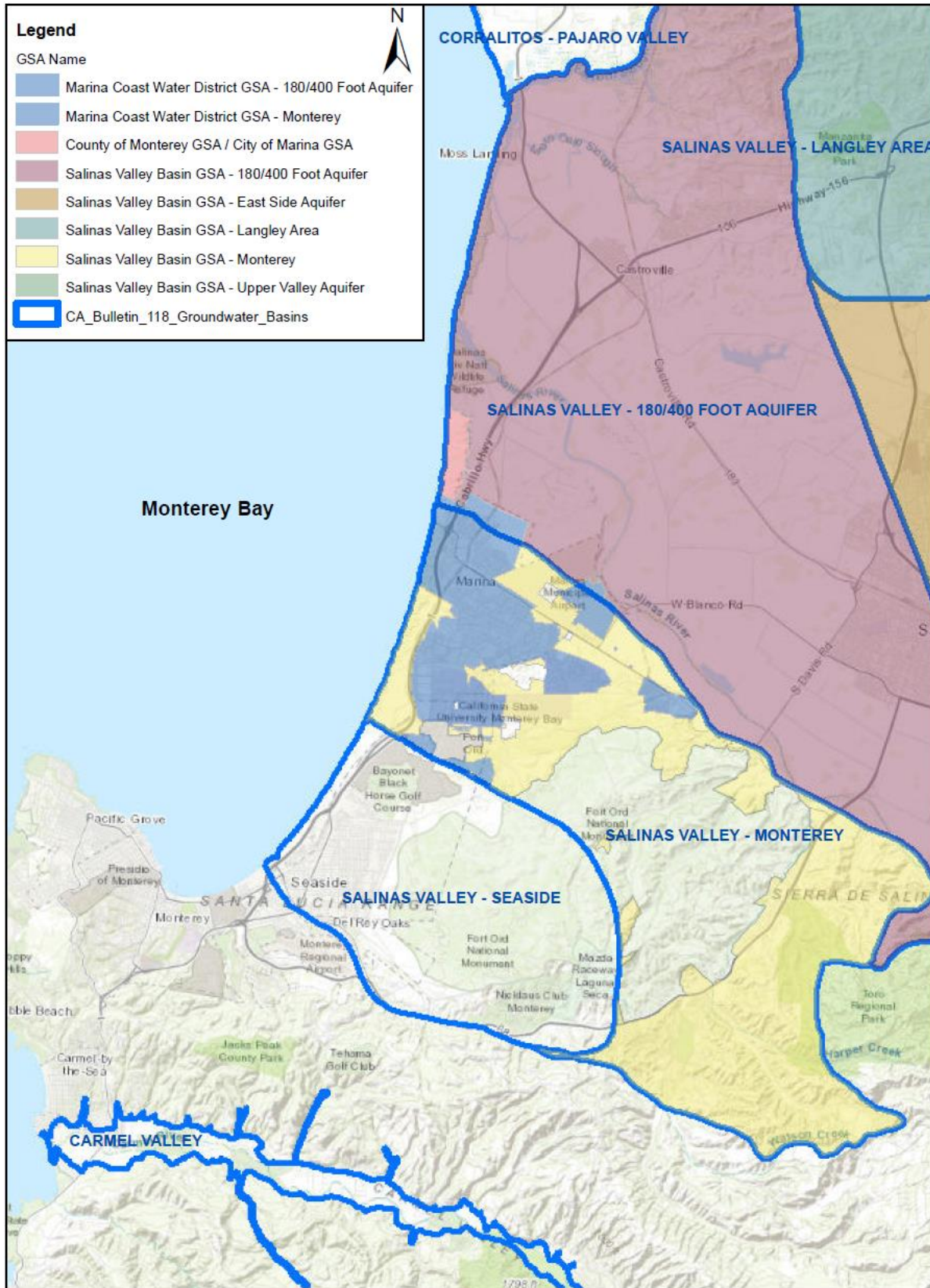

SGMA grants local public agencies the authority to manage groundwater within high- and medium-ranked priority basins and subbasins. The 180/400 Foot Aquifer Subbasin is classified as a high-ranked priority subbasin and in January 2016 was further designated by DWR as a Critically Overdrafted Subbasin. The SVBGSA and City of Marina GSA submitted Groundwater Sustainability Plan (GSP) for that subbasin in 2020. DWR classifies the Monterey Subbasin as a medium-ranked priority subbasin. The GSP for the Monterey Subbasin must be completed by January 31, 2022,¹⁸.

The SGMA “sustainability goal” is defined as “the existence and implementation of one or more groundwater sustainability plans that achieve sustainable groundwater management by identifying and causing implementation of measures targeted to ensure that the applicable basin [or subbasin] is operated within its sustainable yield.” (Water Code, § 10721, subd. (t).) The sustainability goal is to be achieved in the subbasin or basin within 20 years of the implementation of the groundwater sustainability plan. (Water Code, § 10727.2, subd. (b).) “Sustainable yield” is defined as “the maximum quantity of water, calculated over a base period representative of long-term conditions in the basin and including any temporary surplus, that can be withdrawn annually from a groundwater supply without causing an undesirable result.” (Water Code, § 10721, subd. (v), emphasis added.) The required “base period” for purposes of developing groundwater sustainability plans is the period before January 1, 2015. Water Code Section 10727.2(b)(4) states, “[t]he [groundwater sustainability] plan may, but is not required to address undesirable results that occurred before, and have not been corrected by, January 1, 2015.”

Within the 180/400-Foot Aquifer GSP, the following sustainable management criteria are used. The same criteria are being developed for the Monterey Subbasin GSP.

- Chronic lowering of groundwater levels. The objective is to maintain the year 2003 groundwater elevations, which was the recovered groundwater levels following the drought of 18=986-1992. The recovery was aided by supplying recycled water through CSIP starting in 1989. During the drought of 2012-2016, the groundwater levels declined to the same elevations as in 1991.
- Reduction in groundwater storage. The objective is to limit groundwater pumping at the sustainable yield of 112,000 afy.
- Seawater intrusion. The objective is to hold the 500 mg/L chloride isocontour at the 2017 extent. Seawater Intrusion is discussed in Section 5.2.5.

¹⁸ Water Code Section 10720.7(a)(2).

- Degraded groundwater quality. The objective is to have no exceedances of groundwater quality constituents. These include VOC's from clean-up sites, nitrates and naturally occurring minerals.
- Subsidence. The objective is no long-term land subsidence from dewatering water-bearing strata.
- Depletion of interconnected surface water. The objective is maintain and not increase the current average 69,700 afy of surface stream percolation into the groundwater aquifers.

Management strategies to achieve these objectives are discussed in the following section.

5.2.3 Basin Management

Where groundwater basins are in or projected to be in overdraft, the Water Code¹⁹ requires UWMPs to provide detailed descriptions of efforts being undertaken by the urban water supplier to eliminate the long-term overdraft condition. The 180/400 Foot Aquifer Subbasin has been declared by DWR to be in Critical Overdraft. MCWD will actively participate in the GSA formed for that subbasin. MCWD is already taking actions to preserve and protect the groundwater aquifers from which MCWD draws potable water and its continuing ability and right to access groundwater. MCWD is also exploring new alternative water sources to augment groundwater supplies. MCWD is developing a Seawater Desalination Project and a Recycled Water Project, as discussed in Section 5.4.

MCWRA has been and is currently working to eliminate basin overdraft and seawater intrusion. The current program builds upon action taken in the 1940s when MCWRA's predecessor agency, the Monterey County Flood Control and Water Conservation District, initiated development of the Nacimiento and San Antonio dams and reservoirs to augment water resources within the County. From the time it was formed, MCWD has cooperated with the MCWRA to further water resources development within the Salinas Valley.

In 1991 and 1992, MCWRA developed and approved the Monterey County Water Recycling Projects to deliver recycled wastewater for irrigation use in the Castroville area, so that groundwater pumping could be reduced in that area. The project is commonly referred to as the Castroville Seawater Intrusion Project (CSIP). In the project, recycled water is produced and used along the coast in lieu of pumping groundwater for agricultural irrigation. The project has operated successfully since 1998, reducing groundwater pumping and the rate of seawater intrusion.

To further address basin overdraft and seawater intrusion, MCWRA's Salinas Valley Water Project (SVWP) was developed (see Section 5.2.7). The project included modifying the spillway

¹⁹ Water Code §10631(b)(2)

at Nacimiento Reservoir, adjusting the operations of Nacimiento and San Antonio reservoirs to increase releases into the Salinas River, and construction of the Salinas River Diversion Facility (SRDF) near Marina. Water diverted from the river is added to the CSIP distribution system, further reducing the volume of coastal groundwater pumped for agriculture. The projects were completed in 2010, and delivers 1,500 to 5,000 AFY for CSIP. Due to the statewide drought and resultant low water levels in the reservoirs, the SRDF was not operated in 2014 and 2015, but resumed deliveries in 2016.

The Pure Water Monterey Project was recently constructed by Monterey One Water (M1W) and the Monterey Peninsula Water Management District (MPWMD). The project develops new sources of water supply and conveys them to the M1W Regional Treatment Plant, where they are recycled as either Advanced Treated Water for indirect potable reuse in the southern Seaside Groundwater Basin, or as additional Tertiary Treated Water for CSIP. At full capacity, the project is expected to generate up to 4,300 AFY of additional supply for CSIP.

Four additional strategies identified in the GSP for the 180/400 Foot Aquifer Subbasin. The first is increasing in-lieu recharge through direct delivery of irrigation water to replace groundwater pumping. A portion of this is the SVRP plant modification included in the Pure Water Monterey project, to facilitate supplying recycled water in low-demand months. This also includes expanding the CSIP delivery area beyond the current 12,000 acres, and maximizing the use of the SRDF.

The second new strategy is direct aquifer recharge through percolation basins or injection wells. MCWRA holds water right permit 11043 for the diversion of excess flows from the Salinas River. Peak winter flows may be diverted to recharge basins. Another option is to operate the SRDF diversion facility in the winter months, treat the diverted water to potable standards and then inject it directly into the 180/400-Foot Aquifer.

The third strategy is increased recharge through invasive species eradication. Non-native species established on the banks of the Salinas River consume water which historically recharged the aquifer. This is an expansion of an existing program coordinated by MCWRA and executed by the Resource Conservation District of Monterey County.

The final strategy is a seawater intrusion pumping barrier, creating a capture zone along the coast to prevent additional seawater from migrating inland. This would need to be coupled with a regional desalination project so that the diverted flows are placed to beneficial use. As described, this project would extract up to 30,000 afy, so it is significantly larger than the projects later described in Section 5.6.

5.2.4 Integrated Regional Water Management Plan

In 2005, the Monterey County Water Resource Agency, the Marina Coast Water District and the Castroville Water District formed the Salinas Valley Water Management Group to spearhead

regional planning for the Salinas Valley Region of Monterey County. In May 2006, they published the Salinas Valley Integrated Regional Water Management Functionally Equivalent Plan. The plan outlined regional goals, objectives and strategies in the areas of water supply, water quality, flood protection and environmental enhancement. Strategies in the Functionally Equivalent Plan that addressed water supply were the Salinas Valley Water Project, the MCWD Eastern Distribution System and the City of Soledad Water Recycling Project.

In 2012, the Greater Monterey County Integrated Regional Water Management Plan was adopted, replacing the 2006 FEP. That plan includes several water supply projects, including stormwater capture for additional CSIP supply, the Inter-Lake Tunnel Project to connect the San Antonio and Nacimiento Reservoirs, the RUWAP Urban Recycled Water Project, and the initial wells for a Regional Seawater Desalination Project. The most recent update to the plan was in 2018.

In 2013, the Monterey Peninsula, Carmel Bay, and South Monterey Bay Integrated Regional Water Management Plan (IRWMP) was adopted, updating the earlier 2007 Monterey Peninsula IRWMP. In 2019 the plan was again updated. The most recent update added several water supply projects, including a seawater desalination project.

5.2.5 Seawater Intrusion

While sufficient production capacity (versus water availability) to meet the projected ultimate demand within MCWD's service areas can be provided, there is concern that seawater intrusion may eventually degrade water quality in the Marina Area Subbasin where MCWD's wells are located and render all or a number of them unfit for domestic water supplies without further treatment, such as desalination. Similarly, there has been concern that hazardous substance contamination detected at the former Fort Ord might adversely affect the quality of water MCWD is serving within its Marina and Ord Community service areas (discussed in Section 5.2.6).

Seawater intrusion into 180-Foot and 400-Foot aquifers was identified along the coast over 50-years ago. The areas of seawater intrusion may be tracked using chloride concentration. A chloride concentration of 500 milligrams per liter (mg/L) is the upper California Department of Public Health Secondary Drinking Water Standard for chloride (250 mg/L is recommended) and is used as a measure of impairment of drinking water (water above 500 mg/L may still be suitable for non-potable uses). The line of chloride concentration (isohaline) of 500 mg/L water is used as the basis for determining the seawater intrusion front as shown on Figure 5.6 and Figure 5.7. Wells within the intruded areas were progressively moved further inland or into deeper aquifers. Note that these maps trace the timing and location of the "intrusion front" and do not reflect the current condition of groundwater behind the intrusion front.

Historically, MCWD supplied its Marina service area with water from 11 wells (MCWD-1 through MCWD-9, and two replacement wells) screened in the 180-Foot and 400-Foot aquifers.

Between 1960 and 1992, some of those wells indicated varying degrees of seawater intrusion and were replaced, first moving from the 180-Foot aquifer to the 400-Foot aquifer, and later moving to the Deep Aquifer. The District currently has three Central Marina wells in the Deep Aquifer, MCWD-10, MCWD-11 and MCWD-12, constructed in 1983, 1986 and 1989 respectively. These wells are depicted in Figure 3.2.

The U.S. Army's original wells serving the former Fort Ord were located in the Main Garrison area near Marina. When wells indicated varying degrees of seawater intrusion, the Army in 1985 installed four wells further inland. Located near the intersection of Reservation and Blanco Roads in Marina (Figure 3.2), the wells draw from the 180-Foot and 400-Foot Aquifers (well numbers FO-29, FO-30, FO-31 and FO-32). Well FO-32 suffered a screen failure and was shut down in the late 1990s. The District added Wells 34 (in the Deep Aquifer) and Well 35 (in the 400-ft Aquifer) in 2011.

Ongoing monitoring by MCWRA indicates that the seawater intrusion front continues to migrate inland, particularly in the 180-Foot Aquifer, but as discussed below, groundwater conditions behind the front appear to be improving in some areas south of the Salinas River. Based upon the information available at the time, MCWD's 2007 Water System Master Plan identified the need for a phased replacement of wells in the threatened area. Additional data on the migration and extent of seawater contamination can be found in the Final Report Hydrogeologic Investigation of the Salinas Valley Basin in the Vicinity of Fort Ord and Marina, Salinas Valley California, April 2001.

Recent investigations in and around the North Marina Area as part of the Monterey Peninsula Water Supply Project identified an occurrence of freshwater within the shallow dune sand aquifer and the underlying 180-foot aquifer within the area delineated as first experiencing seawater intrusion between 1975 and 1985. Water level data from wells in the shallow dune sand aquifer appear to show protective water levels that are sufficiently above sea level to prevent seawater intrusion in the shallower sediments. This condition, combined with the reduction in pumping in the 180-Foot aquifer in the North Marina Area, appears to have slowed seawater intrusion in this portion of the coastline. Water quality test results for chloride concentrations in the Dune Sand (A-Aquifer) and the 180-ft Aquifer zones is shown in Figure 5.8²⁰.

²⁰ See Technical Memorandum by Hopkins Groundwater Consultants in Appendix E.

Figure 5.6 Historic Seawater Intrusion in the 180-ft Aquifer²¹

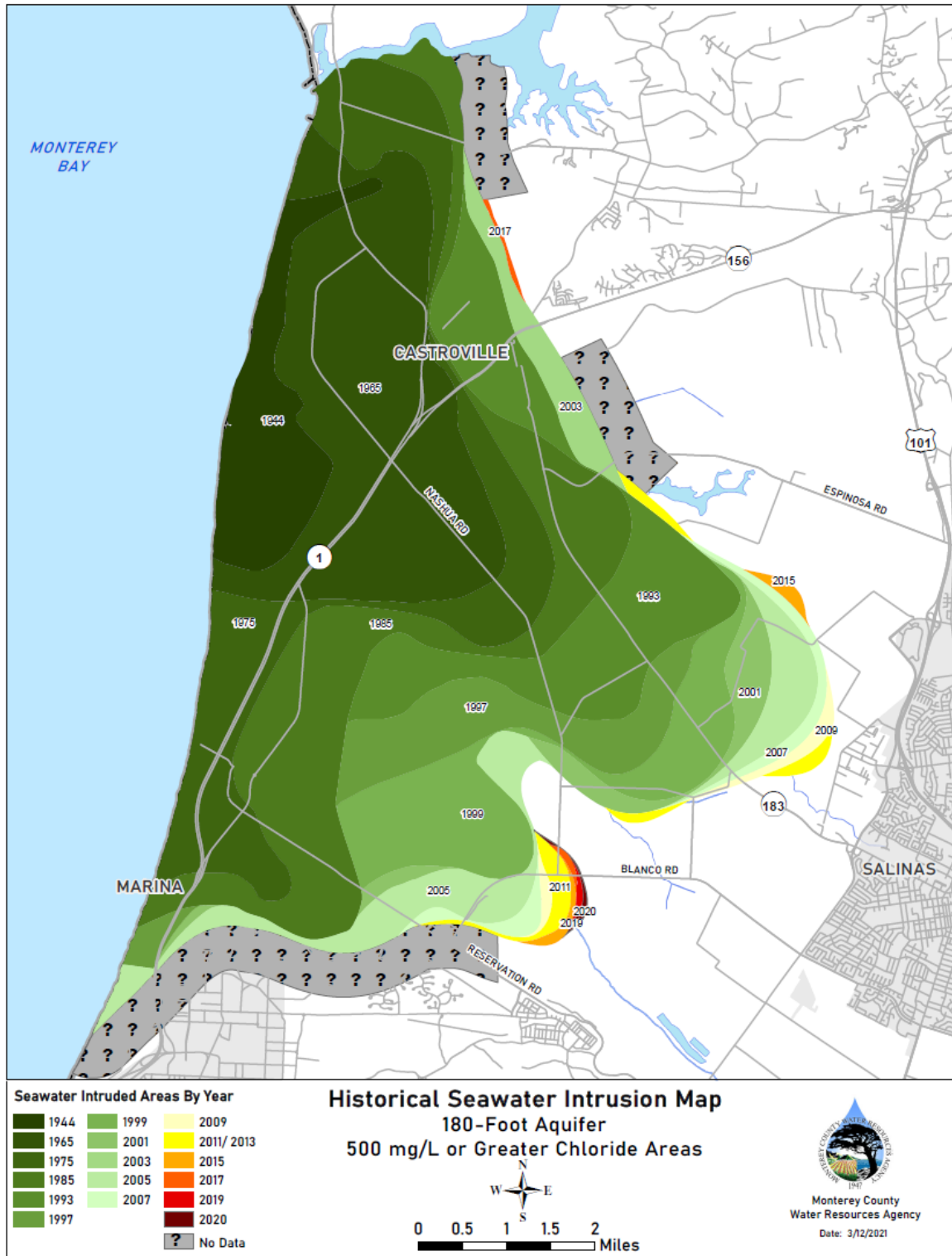

²¹ Source: MCWRA website

Figure 5.7 Historic Seawater Intrusion in the 400-ft Aquifer²²

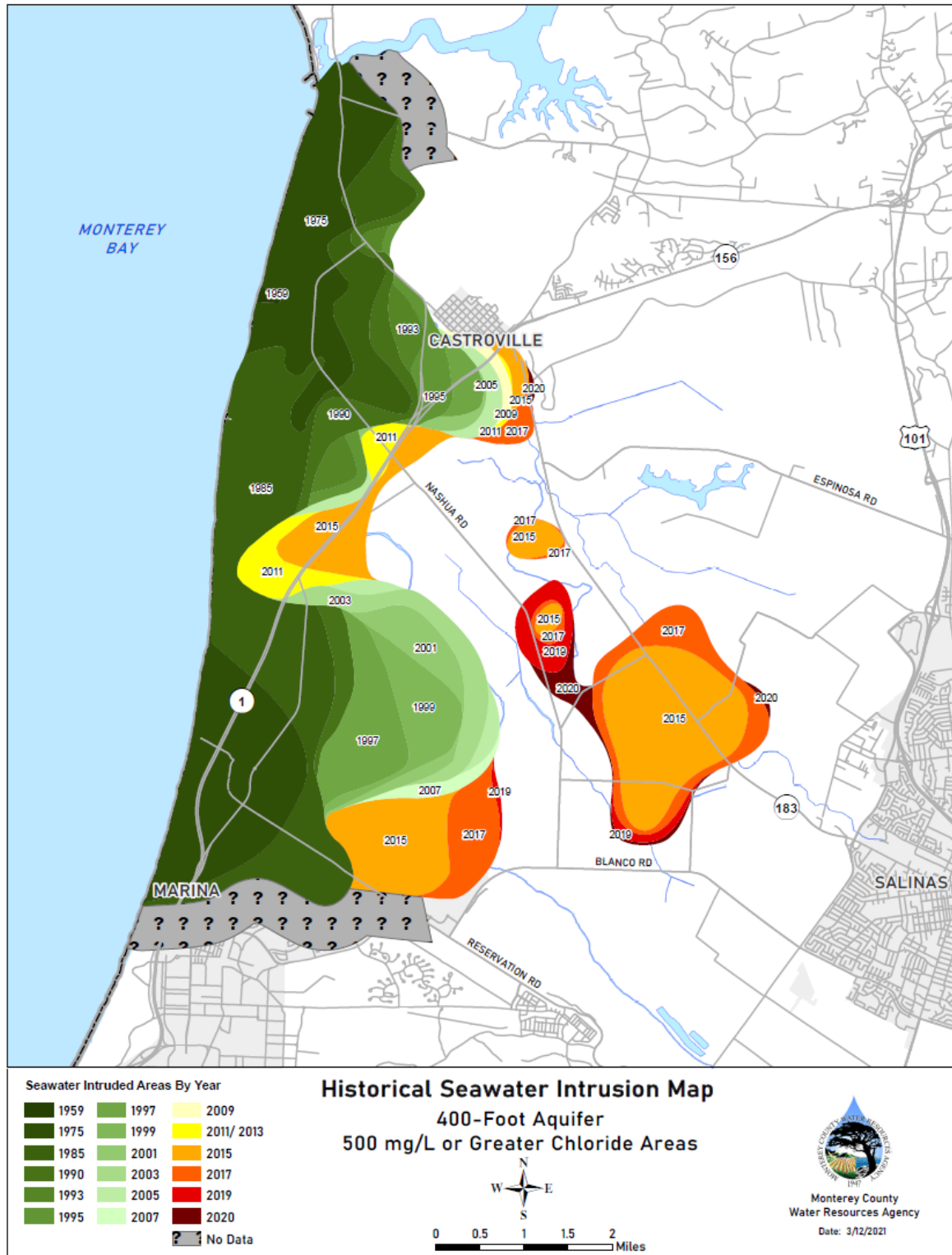

²² Source: MCWRA website

Figure 5.8 Dune Sand Aquifer and 180-Foot Aquifer Chloride Concentration Data²³

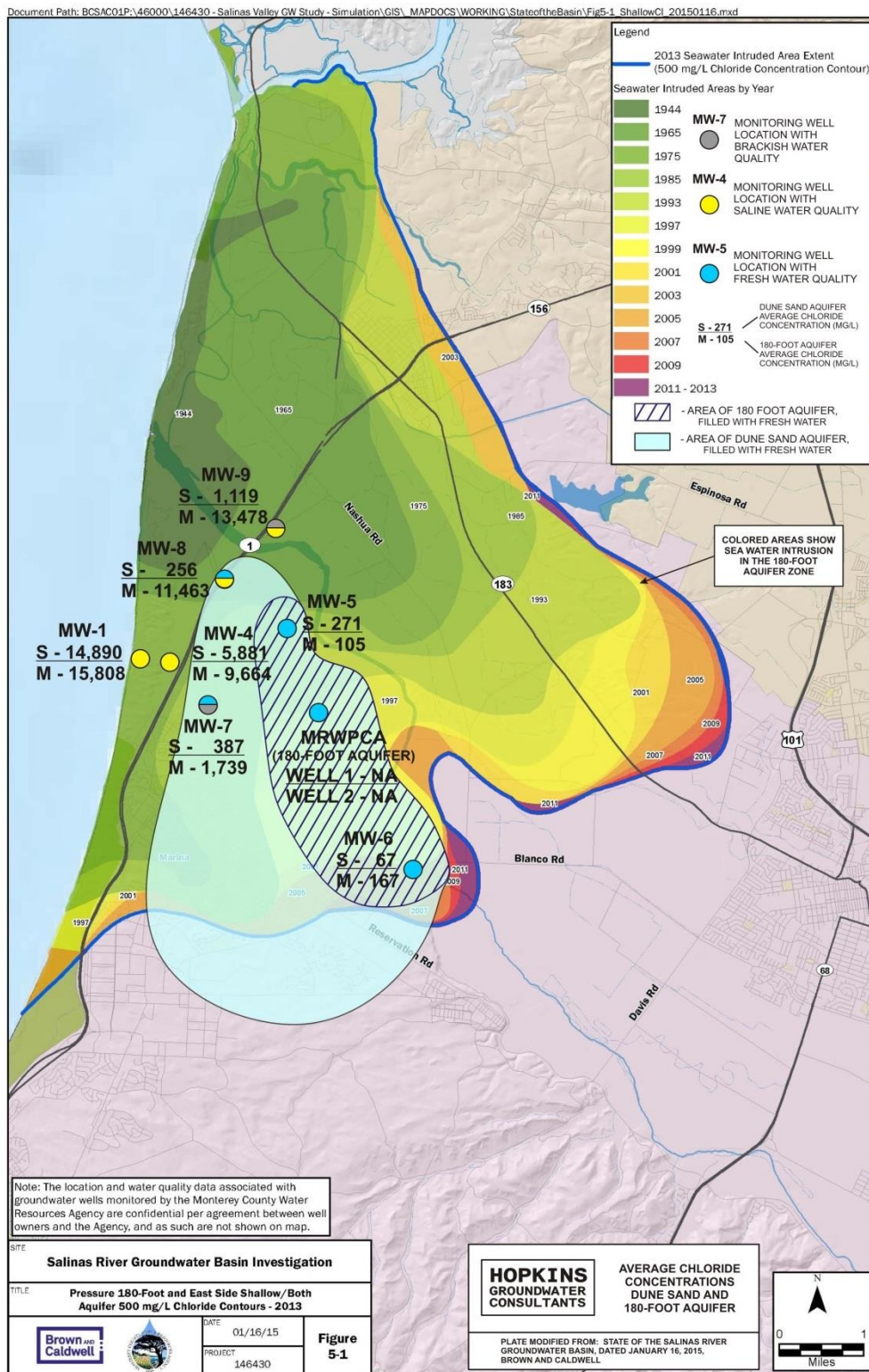

²³ Source: Hopkins Groundwater Consultants, 2016

This recent data may suggest a change of groundwater conditions in this coastal section of the 180-ft Aquifer or they may just reveal the groundwater conditions in an area previously lacking in data. While the freshwater in this area contains salts and nutrients that are derived from overlying land uses that include agriculture, landfill, and wastewater treatment plant and composting facilities, the chemical character is not sodium chloride, which is indicative of seawater. Instead, the chemical character of groundwater in these new wells is calcium chloride and calcium bicarbonate²⁴. Future use of this area for a potable groundwater supply may be unlikely; however, these conditions do show a retardation of seawater intrusion in these shallower aquifer zones in this coastal portion of the Salinas Valley Groundwater Basin, which provides some protection for inland uses of the 180-ft Aquifer.

There is some concern that the Deep Aquifer may become affected by seawater intrusion. MCWD operates a monitoring well installed between the Monterey Bay and the Marina production wells. That monitoring well serves as an early warning system to identify any seawater intrusion that might later affect MCWD's production wells, located further inland. Once identified, the District can install or begin operating one or more back-up wells to replace any potential future loss of production capacity.

It should be noted that water from the deep wells contains acceptable levels of chloride and total dissolved solids, which should not be misinterpreted as a sign of seawater intrusion. This natural salinity does not prevent the use of this water for municipal demands. The levels of chloride (average 99 mg/L) and total dissolved solids (average 390 mg/L) have not increased in the 30-years MCWD has operated the deep wells.

Another concern is that the Deep Aquifer may be connected to, and affect seawater intrusion in, the upper aquifers. Preliminary findings regarding the Deep Aquifer in the Ord Community area indicate that there is some vertical connectivity between the Deep Aquifer and the overlying aquifers. According to the Deep Aquifer Investigative Study, WRIME, May 2003, increased pumping of the Deep Aquifer would be expected to increase the rate of seawater intrusion in the middle and upper aquifers, but to a lesser extent than if the increased pumping occurred in the middle or upper aquifers. In that report, WRIME modeled the effect of increasing groundwater pumping from the Deep Aquifer by two to five times the baseline rate of 4,800 afy. The model predicted that, in the absence of other actions to control seawater intrusion, the landward flow of groundwater would increase as a result.

MCWD is fully cooperating with the MCWRA's program to actively manage and protect the long-term availability of the Salinas Valley groundwater resource. Existing management efforts, reviewed above, include the successful implementation of the Castroville Seawater Intrusion Project and implementation of the annexation agreements that limit groundwater pumping and

²⁴ Ibid.

provide assessment revenue supporting MCWRA's activities to augment Basin water supplies. Those activities include ongoing operation of Nacimiento and San Antonio reservoirs to maximize groundwater recharge through dry-season storage releases that percolate through the Salinas River's streambed. As described in more detail in Section 5.2.7 below, those activities also include the MCWRA's development, approval and implementation of the Salinas Valley Water Project. Implementation of the Sustainable Groundwater Management Act will also better focus groundwater management activities in the Marina Area Subbasin and the adjoining North Marina Area of the 180/400 Foot Aquifer Subbasin.

5.2.6 Groundwater Contamination and Control

The former Fort Ord was identified by the U.S. Environmental Protection Agency (EPA) as a National Priority List federal Superfund site on the basis of groundwater contamination discovered on the installation in 1990. The facility was listed "fence line to fence line," covering all 28,000 acres. Initial investigations pinpointed 39 sites of concern in addition to two Operable Units (the Fritzsche Army Airfield Fire Drill Pit and the Fort Ord landfill) which had been investigated during the 1980s. The sites of concern included motor pools, vehicle maintenance areas, dry cleaners, sewage treatment plants, firing ranges, hazardous waste storage areas, and unregulated disposal areas. An additional two sites were added during the investigation process: one, a defueling area located at Fritzsche Army Airfield; the other, a fire drill burn pit in East Garrison. In all, 43 sites were investigated.²⁵

In 2001, trichloroethylene (TCE), a cleaning solvent, was detected by the Army in one of the three water supply wells at the former Fort Ord. Subsequently, upon the transfer of ownership of the well to MCWD, MCWD also detected the presence of TCE in June 2002. TCE levels detected are below the Maximum Contaminant Levels (MCL) for potable use. The contamination is coming from an abandoned landfill and a fire training pit that were formerly used by the Army, but are now closed. The Army has responded to the landfill contamination problem by installing extensive groundwater cleanup systems to remove the contamination and prevent its further migration. The Army has also been monitoring groundwater quality at the former Fort Ord for a number of years to better understand the location and movement of groundwater contamination caused by the closed landfills.

State and federal safe drinking water MCL standards for TCE are set at 5.0 parts per billion, or approximately ten times higher than detected. Detection of TCE, even at the low concentration levels, was reported by MCWD, as required by law, to the California SWRCB Division of Drinking Water (DDW). No additional action was deemed necessary by DDW because the concentration levels are well below the MCL of 5.0 parts per billion. Both MCWD and the Army regularly monitor the former Fort Ord wells to assess concentration changes. The 2020 TCE

²⁵ www.Fortordcleanup.com Mactec Engineering and Consulting, Inc.

detections in the Ord Community wells ranged from non-detect to 1.9 parts per billion²⁶. TCE detections have been intermittent since the initial detection in 2001.

MCWD continues to monitor the affected well, and all other wells, for TCE and other contaminants on a regular basis. Any changes in contaminant plume migration due to increased MCWD pumping will be monitored and appropriate actions taken. MCWD maintains close coordination with the U.S. Army Corps of Engineers, who manages groundwater cleanup efforts on the former Fort Ord. The Corps of Engineers recently published an update to their mitigation program, depicted in Figure 5.9.

The Defense Department is required by law to clean up contamination to below allowable contaminant levels set by the State Department of Public Health as a public health protection measure. Groundwater samples are taken quarterly and compiled in annual status reports. Additionally, all data is summarized in documents known as five-year reviews. It is expected that final groundwater cleanup may take another 30 years to complete. Additional information on groundwater cleanup and other base contamination remediation actions can be found at www.fortordcleanup.com.

Because Fort Ord is on the National Priority List, section 9604(i) of the federal Superfund law (Comprehensive Environmental Response Compensation and Liability Act, or “CERCLA”) requires the federal Agency for Toxic Substances and Disease Registry (“ATSDR”) to complete an assessment of whether any hazardous substances at the site pose a threat to human health. ATSDR analyzed whether hazardous substances released at Fort Ord might threaten human health by contaminating drinking water wells serving Marina and Ord Community. ATSDR’s final health assessment concludes as follows:

- There are no detections of groundwater contaminants at levels of health concern in the presently “active” drinking water wells on Ord Community. The water at Ord Community is safe to drink. Because the drinking water wells currently in use in the Ord Community are located far from sources of contamination, drilled to deep aquifers that are not likely to be contaminated, and monitored regularly, the Ord Community’s drinking water supply should be safe to drink in the future.
- Because the concentration of groundwater contamination detected in the past in the Ord Community and Marina drinking water wells was low and the duration of exposure was short, adverse health effects will not likely result.

²⁶ EPA test method 524.2 is accurate to +/- 20%.

Figure 5.9 Groundwater Contamination Plumes²⁷

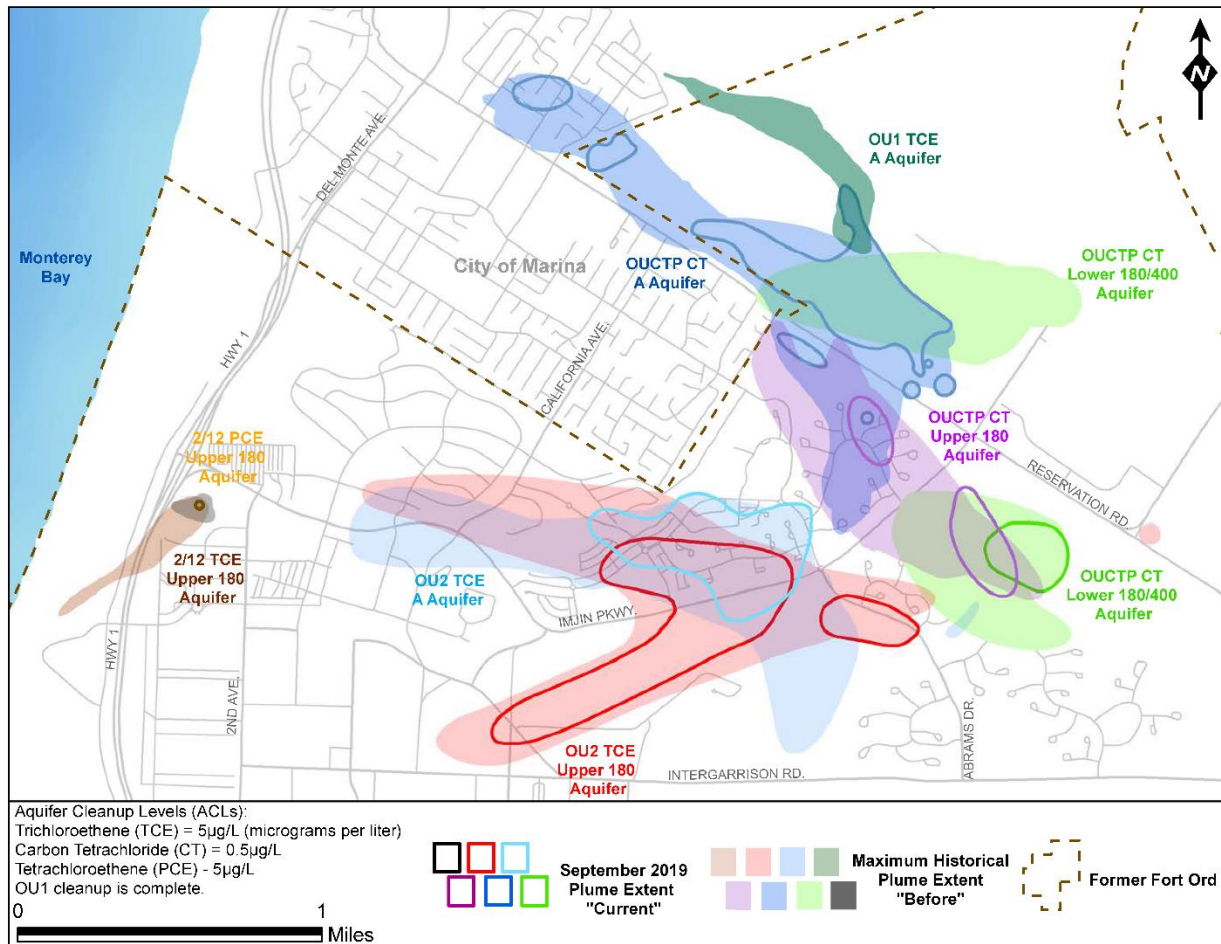

- The water supplied by drinking water wells presently used by Marina is safe to drink. Further, because Marina’s drinking water wells are drilled to deep aquifers and the quality of the water is monitored regularly, Marina’s drinking water should be safe to drink in the future.²⁸

The Salinas Basin has experienced nitrate contamination, a pollutant coming primarily from animal confinement activities (dairies, feedlots) and from irrigated agriculture, sewage treatment plant effluent and septic tanks. This contaminant is a concern, particularly in upper reaches of the 180-Foot Aquifer. Although certain wells in the Salinas Valley have exceeded the state health standard of 45 mg/L of nitrate as NO₃, nitrate levels in the 400-Foot Aquifer are low due to intervening clay layers between the 180-Foot and 400-Foot aquifers.

²⁷ Source: U.S. Army Corps of Engineers, Fort Ord Office, updated 2019

²⁸ See ATSDR Public Health Assessment, Fort Ord, Marina, Monterey County, California (Community Health Concerns and Potential Pathways of Exposure).

No nitrate contamination is evident in, or in the vicinity of, any of the MCWD's wells. Due to the location of the nitrate sources at or near the ground surface, remote from MCWD's wells, with contamination in only the upper reaches of the shallowest, 180-Foot Aquifer, nitrate contamination does not pose a threat to MCWD's sources of groundwater supply.

5.2.7 Salinas Valley Water Project

MCWRA has maintained and operated Nacimiento and San Antonio reservoirs since they became operational in 1957 and 1967, respectively. The operation of both reservoirs has been, and continues to be, for two primary hydrologic functions: flood control and conservation, i.e. the storage and release of runoff to recharge the Salinas Valley Groundwater Basin via the Salinas River.

On June 4, 2002, the MCWRA adopted a basin-wide program, known as the Salinas Valley Water Project (SVWP or Project), to continue addressing water supply issues in the Salinas Valley Groundwater Basin. The objectives of the SVWP are:

- Halting seawater intrusion;
- Continuing conservation of winter flows for recharge of the Salinas Valley basin through summer releases;
- Providing flood protection;
- Improving long-term hydrologic balance between recharge and withdrawal; and
- Providing a sufficient water supply to meet water needs through the year 2030.

The SVWP was specifically developed to provide for the long-term management and protection of groundwater resources in the Salinas Valley Groundwater Basin by: (1) providing a source of water to the Basin by reoperating Nacimiento and San Antonio reservoirs and capturing water via a seasonal surface diversion structure to provide water for agriculture; and (2) maintaining present conservation release practices to recharge the groundwater basin.

The Project includes reoperation and maintenance of the Nacimiento and San Antonio reservoirs, modification of the spillway at Nacimiento Dam, and installation of a rubber inflatable dam on the Salinas River near Marina to allow for rediversion of about 10,000 acre-feet of reservoir releases to be made available in lieu of groundwater pumping for irrigation. In total, by 2030 an additional yield of 37,000 afy is expected.

The Salinas Valley Water Project EIR anticipated that water demands on the basin would decline by about 20,000 afy, from 463,000 afy in 1995 to 443,000 in 2030, due to urban and agricultural conservation efforts, conversion of agricultural lands and some crop shifting.²⁹ This overall

²⁹ Salinas Valley Water Project, Draft Master EIR, 1998, p. 3-15

decline was expected to occur despite the projected doubling of the population served by the Salinas Valley Groundwater Basin, from 188,949 in 1995 to 355,829 in 2030. The reported SVGB pumping in 2019 was 450,423 ac-ft, with an estimated population of 350,000. Irrigated acreage was approximately equal, with 173,200 acres in 1995 and 177,700 acres in 2019. Water demand for agriculture varies with the weather, peaking in drought years (see Figure 5.10). While the anticipated decline in urban water demand has borne out, agricultural demand has remained steady as growers have increased their crop production per acre.

Figure 5.10 Salinas Valley Groundwater Pumping, 1995-2019³⁰

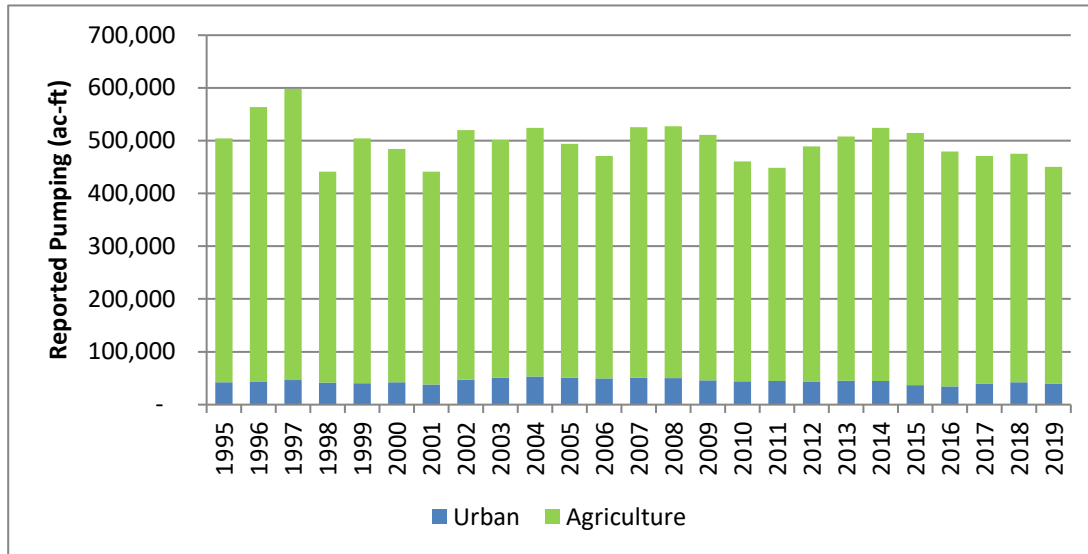

The Project was constructed in 2008 to 2010, and the Salinas River Diversion Facility was placed in operation in April 2010. Due to the state-wide drought that began in 2013, the SRDF was not operated in 2014 or 2015. The project has delivered up to 5,000 afy, so it is unlikely it will be sufficient to halt seawater intrusion in the 180/400 Foot Aquifer Subbasin of the Salinas Basin. The project has helped slow the advance of intruded groundwater, as can be seen on Figure 5.6.

5.3 Water Transfer and Exchange Opportunities

MCWD does not share a boundary with other wholesale or retail water suppliers on its west, north or eastern boundary, but it does share boundaries with Seaside Municipal Water System and the California American Water Company – Monterey Service Area (CAW) along MCWD’s southern boundary. Under current law, water supply from the Salinas Valley Groundwater Basin cannot be exported to customers in other basins³¹. Therefore, any connections made must be for emergency use only or of a “zero-balance type” (volume added must equal volume withdrawn).

³⁰ MCWRA Annual Groundwater Extraction Summary Reports, 1995 to 2019

³¹ Monterey County Water Resources Agency Act, Section 52-21

In 2008-2009, the District constructed a new water main in General Jim Moore Blvd to serve the southern portion of the Ord Community, particularly Del Rey Oaks which is at the southern end of General Jim Moore Blvd. At that time, CAW was working with the Monterey Peninsula Water Management District to develop an aquifer storage and recovery project for the Seaside Groundwater Basin, with injection wells located at the northern end of General Jim Moore Blvd. A joint-use agreement was entered into by MCWD and CAW for this new pipeline. Under the agreement, both agencies meter the amount of water added to and taken from the pipeline. The system must be managed to a net zero-balance in accordance with current law.

In the Water Supply Assessment for the Campus Town Specific Plan (City of Seaside), one of the water supply options for the project is providing in lieu recharge for the Seaside Groundwater Basin by converting the Bayonet/Blackhorse Golf Course to recycled water supply, and the City then providing water from the Seaside Groundwater Basin back to MCWD to supply the project. The golf course irrigation currently comes from City-owned wells in the Seaside Groundwater Basin, while the domestic supply for the golf course facilities comes from MCWD. The City obtained the approval of the Seaside Watermaster for this in February 2020³². The volume of potable supply needed for the specific plan area is less than the volume of irrigation supply used for the golf course, so this would potentially benefit both the project and the Seaside Groundwater Basin water balance.

Additional transfer opportunities exist within the Salinas Valley Groundwater Basin. MCWD could purchase the rights to existing groundwater supplies currently used elsewhere in the Salinas Valley and transfer the water to the District service area. This would require curtailment or reduction of well pumping on the donor land to allow increased pumping from District wells. Such transfers would have to be performed on a willing-seller, willing-buyer basis and with the cooperation of the Salinas Valley Groundwater Sustainability Agency and the Monterey County Water Resources Agency.

5.4 Future Water Supply

Looking at the projected demands in Table 5.3, the total Ord Community groundwater supply of 6,600 afy is sufficient to meet the projected year 2040 water demand of 6610 afy. However, certain jurisdictions have projected shortfalls and other have projected surpluses. The jurisdictions shortfalls sum to 1,398 afy in 2040. A portion of that shortfall will be met by using recycled water for landscape irrigation. The Central Marina service area is not projected to exceed its current SVGB groundwater allocation within the planning period.

³² Agreement for Storage and Recovery of Non-Native Water From the Seaside Groundwater Basin, February 5, 2020.

Table 5.3 Ord Community Groundwater Shortfalls

Jurisdiction	2040 Demand	Allocation	Shortage*
U.S. Army	471	1,562	0
CSUMB	977	1,035	0
Del Rey Oaks	238	243	0
City of Monterey	130	65	65
County of Monterey	522	710	0
UCMBEST	408	230	178
City of Seaside (Ord Portion)	1,698	1,012	686
State Parks and Rec.	9	45	0
City of Marina (Ord Portion)	1,809	1,340	469
Assumed Line Loss	348	348	NA
Total	6,610	6,600	1,398

* Jurisdictions with surpluses are shown with 0 shortage.

As discussed in the following subsections, MCWD has been actively working towards developing additional water supplies to meet the needs of the Ord Community. This new supply will come in the form of recycled water for urban landscape irrigation and desalinated water for potable demand. Table 5.4 shows the projected use of recycled water, as described in the Environmental Impact Report for the Regional Urban Water Augmentation Project. In the table, the desalination supply is the net potable shortfall after recycled water is supplied. Expanded tables showing demands by jurisdiction are in Appendix C.

Table 5.4 Projected Demand by Source (afy)

	2020	2025	2030	2035	2040
Groundwater	3,367	5,391	6,540	7,335	7,821
Recycled Water	0	600	953	1,140	1,270
Desalinated Water	0	0	299	394	483
Total Demand	3,367	5,991	7,792	8,869	9,574

5.4.1 Regional Urban Water Augmentation for the Ord Community

FORA's 1997 Final EIR, Reuse Plan and Master Resolution projected that redevelopment of the former Fort Ord would add approximately 8,700 new residential dwelling units and 4.9 million square feet of commercial/industrial development by the year 2015. Total water demand on the base was projected to be 9,000 afy. The water supply mitigation target in the Final EIR is 2,400 afy, calculated as the difference between the total demand and the 6,600 afy of existing groundwater supply ($9,000 - 6,600 = 2,400$). That original estimation assumed that the Bayonet/Blackhorse Golf Course would continue to be supplied by wells in the Seaside Groundwater Basin.

From 1998 to 2020, there have been 1,300 new dwelling units constructed and just under 1.0 million square feet of commercial development within the Ord Community (in addition to renovation of existing facilities and construction of over 500 replacement dwelling units). The

development projections in this plan show an additional 12,300 dwelling units and 13 million square feet of institutional and commercial development being added over the next 20 years. The projected total water demand in the Ord Community is 6,610 afy in the year 2040. However, the sum of the projected supply shortfalls of the separate jurisdictions is about 1,400 afy. A portion of this projected future development will be considered above the amount mitigated under the Base Reuse Plan Final EIR.

MCWD's water supply plans include utilizing a combination of recycled water and desalination to meet the Ord Community's future demands as identified in the Fort Ord Base Reuse Plan. These plans are further described in MCWD's Environmental Impact Report for the Regional Urban Water Augmentation Project (RUWAP), certified in October 2004, and later amended in October 2006, February 2007 and April 2016. The RUWAP proposes to provide an additional water supply of 2,400 afy for the Ord Community area (also known as the former Fort Ord military base) as identified in the Fort Ord Reuse Plan. When the RUWAP EIR was prepared, it included the golf course in the list of potential recycled water customers, but did not increase the project size to account for the additional demand (approximately 500 afy).

The Water Augmentation Project as evaluated in the RUWAP EIR consisted of two distinct alternatives and one hybrid alternative. One alternative considered was wastewater recycling, and the other was desalination of seawater-intruded groundwater. The hybrid alternative was equal amounts of recycled and desalinated water (1,500 afy desalination, including incorporation of the currently idle desalination plant producing 300 afy and 1,500 afy of recycled supply).

On June 10, 2005, the MCWD and FORA boards of directors endorsed the "hybrid alternative" from the October 2004 Regional Urban Water Augmentation Project EIR and directed the staffs to begin scoping to develop specific plans for the additional 2,400 afy of supply to MCWD, with 300 afy of recycled water available to the Monterey Peninsula. The hybrid alternative includes a recycled water component and a desalinated water component. In 2007, the EIR was amended to increase the recycled water component to a maximum of 1,727 afy (1,427 for the Ord Community plus 300 afy for the Monterey Peninsula), with the total project remaining at 2,400 afy. Also in 2007, the Fort Ord Reuse Authority allocated the project's recycled water component among the land use jurisdictions in the Ord Community, as shown in Table 5.5.

Table 5.5 Recycled Water Allocations (afy)

Jurisdiction	Allocation
U.S. Army	0
CSUMB	87
Del Rey Oaks	280
City of Monterey	0
County of Monterey	134
UCMBEST	60
City of Seaside (Ord Portion)	453
State Parks and Rec.	0
City of Marina (Ord Portion)	345
Assumed Line Loss	68
Total	1,427

In 2012, Monterey One Water and the Monterey Peninsula Water Management District began planning the Pure Water Monterey Groundwater Replenishment Project, as described in Section 5.5.2, which includes the advanced treatment of recycled water for indirect potable reuse.

On April 8, 2016, MCWD and M1W entered into an agreement which would provide up to 1,427 AFY of advanced treated water for urban landscape irrigation instead of the tertiary treated recycled water planned under the RUWAP. To address the remaining (potable) water augmentation under the Base Reuse Plan, MCWD, FORA, and M1W entered into a memorandum of understanding on May 13, 2016, to explore the most cost effective and technically efficient mix of advance treated water, conservation, desalination, groundwater recharge and recovery, and other water sources, options, and alternatives to provide the additional 973 afy for the Ord Community. The recommended option under that study was Indirect Potable Reuse through the expansion of the Pure Water Monterey Advanced Water Purification Plant and injection into the Deep or 400-ft aquifers.

5.4.2 Surface Water Supplies

The District is located along the Salinas River, and MCWD Board of Directors has considered purchasing surface water rights in the Salinas River Basin as a means of meeting long-term (beyond 2030) demands. MCWD has also studied the possibility of constructing a surface water treatment plant, which would utilize surplus Salinas River water. That option is available to meet additional demands beyond the 20-year planning horizon. Also, Phase II of the Salinas Valley Water Project, examined at a programmatic level in the SVWP EIR, calls for surface water to be made available to coastal urban water agencies in the future. MCWRA holds an undeveloped water right permit 11043 with a priority date of July 11, 1949, for diversion of up to 135,000 afy from the Salinas River, at a peak rate of 400 cfs (peak winter flows). The SVBGSA identified has proposed diverting winter flows under this water right and percolating it into the East Side Aquifer Subbasin, which would benefit the 180/400-Foot Aquifer Subbasin as well. However, the State Water Resources Control Board amended the permit in 2013, setting a

deadline of July 1, 2026, for completing the planning, permitting and construction of the intake and initiating diversions under the permit.

5.4.3 Stormwater Capture

The surface geology within the District service area is predominantly coastal dune sands, and stormwater disposal is primarily through the use of percolation basins. Within portions of the former Fort Ord there were stormwater collection systems that conveyed runoff to the Monterey Bay. These outfalls have been converted to on-shore percolation basins, and most of the areas served have been converted to local percolation ponds. Local percolation recharges the shallow, unconfined aquifer, with a portion of that reaching the 180-ft aquifer.

Because the existing stormwater systems are decentralized, terminating at numerous small percolation lots, stormwater capture for municipal use is not currently planned as a water source. In neighboring communities such as Pacific Grove, summer urban runoff is diverted to the sanitary sewer system to reduce discharges to the Monterey Bay, which also increases the amount of recycled water produced at the regional wastewater treatment plant. Capture of peak urban runoff during the winter months has the potential to cause sanitary sewer system overflows, so any diversions require control systems that coordinate with the wastewater collection system.

5.4.4 Future Water Supply Assessments and Written Verifications of Supply

In the Ord Community the FORA Final EIR, Reuse Plan and Master Resolution provide mitigation for the initial redevelopment of the former Fort Ord. The 2,400 afy of new water supply mitigation was intended to meet the additional water demands projected to occur by the year 2015. On June 10, 2005, the MCWD and FORA board of directors endorsed the “hybrid alternative” from the September 2004 Regional Urban Water Augmentation Project EIR. This Project need is consistent with water required by the existing Fort Ord Base Reuse Plan. Additional development above the amount addressed in the Base Reuse Plan EIR will require separate environmental review and potentially additional water supply, which must be funded by the project proponent. The 2040 supply shortfall is 1,753 afy, of which 1,270 afy is projected to be met with recycled supply under the RUWAP. No assumption is made here regarding reallocation of groundwater within the Ord Community, as each jurisdiction may foresee development beyond the 20-year planning horizon of this report. MCWD will continue to track actual development’s consumption of water against estimates in order to plan supplemental supplies as may be necessary.

The water augmentation recycled supply is expected to be on-line by 2022 (construction of the distribution is on-going in 2021). MCWD has not yet considered this supply to be “available” in its written verifications of supply because it does not meet the legal requirements to support tract map approvals, building permits or will-serve letters under SB 221. MCWD currently issues water supply verifications under the requirements of SB 221 and will-serve letters based on final

subdivision map phases considering only that water which is currently available (SVGB and Marina desalination supply), up to the point where a given land use jurisdiction's allocation is fully allocated to projects. For purposes of this UWMP and requirements of SB 610 water supply assessments, the water augmentation supply is considered available for planning purposes within the 20 year time frame of the UWMP.

5.5 Recycled Water

MCWD operates two wastewater collection systems serving the City of Marina and the Ord Community, which then connect to an interceptor pipeline operated by Monterey One Water (M1W). Central Marina connects via a dedicated pump station. The total flow at that station was approximately 1,200 afy in 2020. The Ord Community connects via a gravity pipeline with a metering flume. The total flow at the flume was approximately 970 afy in 2020. The interceptor system conveys wastewater to the M1W Regional Treatment Plant (RTP) north of Marina. The RTP treats wastewater collected from multiple communities in Monterey County, from Pacific grove to Moss Landings along the coast and inland to the City of Salinas. In 2020, municipal wastewater flows to the RTP were 19,000 afy, with MCWD contributing about 11%. Wastewater is treated to secondary treatment standards at the RTP facilities and that water not designated for further treatment and recycling is discharged via an ocean outfall. Water designated for further treatment is conveyed to either Salinas Valley Reclamation Plant (SVRP) or the Advanced Water Purification Facility, as discussed below.

5.5.1 Tertiary Treated Recycling Systems

The SVRP is capable of producing an average of 29.6 mgd of recycled water or about 33,000 afy. It currently produces about 14,000 AFY of tertiary-treated recycled water meeting the standards of Title 22 of the California Code of Regulations. The recycled water is delivered to the Castroville Seawater Intrusion Project (CSIP), irrigating farmland in the greater Castroville area, reducing demands on Salinas Valley groundwater and retarding seawater intrusion in that area. In 2020, 12,560 acre-feet of tertiary-treated water was delivered for crop irrigation. As agricultural demands are seasonal, this capacity cannot be fully utilized year round. To increase recycled water yield based on current wastewater flows, storage capacity to capture winter flows for summertime use would be required. As wastewater flows increase due to urban development, additional recycled water may be produced.

While MCWD has senior rights to recycled water through its agreement with the M1W, MCWD does not currently use recycled water within its two service areas.³³ In 1989, MCWD entered into an annexation agreement with M1W for wastewater treatment. This agreement established MCWD's first right to receive tertiary treated wastewater from the SVRP. MCWD has the right

³³ MCWD was the first agency to contract for recycled water with the M1W, preceding subsequent contracts by others for recycled water supply.

to obtain treated wastewater from M1W's regional treatment plan equal in volume to that of the volume of MCWD wastewater treated by M1W and additional quantities not otherwise committed to other uses.

MCWD operated its own water reclamation facility from 1994 to 1997 at its former wastewater treatment plant, under the California Regional Water Quality Control Board (RWQCB) Waste Discharge Requirement (WDR) No 91-95 and Monitoring Report No. 92-95. These water reclamation requirements specify the user sites, water quantity, water quality, and a monitoring and reporting program. In 1997 MCWD discontinued production at its water reclamation facility and directed the raw wastewater flow to the M1W RTP under the annexation agreement.

MCWD and M1W have been jointly pursuing an urban recycled water project,³⁴ which forms the recycled water alternative in the Regional Urban Water Augmentation Project. Planning for this project found that a total of 1,727 afy could be made available for urban use without adding seasonal recycled water storage (Phase 1 Project). 1,427 afy of recycled water would be supplied for urban irrigation within the Ord Community, and the remaining 300 afy could be used in other jurisdictions on the Monterey Peninsula. MCWD's right to purchase recycled water has a contractual upper limit in the summer months, so providing this volume of recycled water supply requires the commitment of summertime flows from M1W and MCWRA. Seasonal storage would allow recycled water, for which there would otherwise be little demand during the winter, to be made available for irrigation demands in warmer months, rather than discharging treated wastewater to the ocean. Projected Phase II demands that could be served through additional distribution lines and seasonal storage facilities could bring the total recycled water demand to about 3,000 afy, with 2,171 afy of demand that could be served within MCWD.

In 2006, the District began design of the recycled water system. In the Basis of Design Report, the projected non-potable water demands were recalculated, as shown in Table 5.6. Potential Phase 1 uses generally included planned or existing landscapes along the recycled trunk main alignment, such as the existing Bayonet/Blackhorse Golf Course in Seaside, the sports fields at CSUMB, and the proposed golf resort in Del Rey Oaks. The total of existing irrigation demands (2,235 afy, see Table 5.6) exceeds the size of the Phase 1 project (1,427 afy, see Table 5.5), which targets customers along the main pipeline route. Potential Phase 2 uses generally include planned or existing landscapes that required construction of lateral pipelines from the trunk main. Potential customers identified but not included in the Phase 1 project may be included in the future Phase 2.

³⁴ Regional Urban Recycled Water Distribution Project Report, RBF, 2003.

Table 5.6 Non-Potable Water Demand Projections (ac-ft/yr)

Jurisdiction	Phase 1	Phase 2	Total
U.S. Army		38	38
CSUMB	202	109	311
Del Rey Oaks	338		338
City of Monterey			0
County of Monterey	47	614	661
UCMBEST	55		55
City of Seaside (Ord Portion)	806	140	946
State Parks and Rec.		5	5
City of Marina (Ord Portion)	435	391	826
Marina Sphere			0
Marina Central	52	87	139
Subtotal	1,935	1,384	3,319
Outside MCWD	300	59	359
Total	2,235	1,443	3,678

Under the RUWAP EIR, the Recycled Water Project was resized to 1,727 afy, with 1,427 afy going to the Ord Community and 300 afy going to the Monterey Peninsula. Phase 2 of the project was not addressed in the EIR, but remains an available demand management strategy for both MCWD and California American Water.

MCWD, in coordination with the M1W and MCWRA as part of its Water Augmentation Project, constructed a recycled water transmission line through Marina, the Ord Community, and into the City of Seaside, taking advantage of opportunities to install pipelines while roads were being reconstructed by the Fort Ord Reuse Authority. The pipeline was completed in 2019 and placed in operation in 2020 as part of the Pure Water Monterey Project, discussed below. MCWD is currently constructing the recycled water distribution system. The existing water recycling systems are shown on Figure 5.12, which is at the end of the recycled water section.

Subject to Monterey County Department of Environmental Health and State Department of Public Health approval, MCWD requires the installation of recycled water pipelines to serve all recreational and common irrigated open space areas within new developments (MCWD Code § 4.28.030, Recycled Water Service Availability). This requirement is waived only when the land use jurisdiction indicates that future recycled water will not be allocated to a project. The City of Seaside has adopted a more restrictive standard, requiring residential front yards to be plumbed for future recycled water in addition to recreational and common areas.

5.5.2 Pure Water Monterey Project

The Pure Water Monterey Groundwater Replenishment Project was constructed by Monterey One Water (M1W) and the Monterey Peninsula Water Management District (MPWMD), with cooperation from MCWD, MCWRA and the City of Salinas. The project develops new sources of water supply and conveys them to the M1W Regional Treatment Plant, where they are

recycled as either Advanced Treated Water for indirect potable reuse in the Seaside Groundwater Basin, or as additional Tertiary Treated Water for CSIP. The project is expected to off-set approximately 4,300 AFY of groundwater pumping for irrigation in the 180/400 Foot Aquifer. The groundwater replenishment component replaces the M1W's previously planned urban recycled water deliveries to the Monterey Peninsula under RUWAP.

The sources of supply identified in the Pure Water Monterey project include: secondary-treated municipal wastewater which is currently discharged to the ocean outfall (i.e., winter flows); agricultural wash water from vegetable processing, which is currently treated at the Salinas Industrial Wastewater Treatment Facility (SIWTF); urban run-off from the City of Salinas and City of Monterey; and surface water diversions from the Blanco Drain and the Reclamation Ditch, which primarily carry agricultural tile drainage during the summer months. All of these flows are conveyed to the regional treatment plant, most using available capacity in the existing wastewater interceptor system and at the Salinas Pump Station (SAPS). An Advanced Water Purification Facility (AWPF) was constructed within the M1W property north of Marina. Advanced Treated Water for indirect potable reuse is conveyed to the Seaside Groundwater Basin, and the additional tertiary-treated recycled water is conveyed to irrigators using the existing CSIP system. A simplified diagram of the project is provided in Figure 5.11.

The proposed alignment for the Pure Water Monterey advanced treated water pipeline was the same as for the MCWD RUWAP recycled water trunk main, so the two agencies agreed to share a single pipeline and deliver advanced treated water for urban irrigation instead of tertiary-treated recycled water as originally planned. Due to the size and length of the trunk main, combining the two projects results in a significant cost savings. The source water for the MCWD portion of the project is the municipal wastewater which was originally slated for tertiary treatment.

On April 8, 2016, MCWD and M1W entered into the Pure Water Delivery and Supply Project Agreement wherein the Product Water Conveyance Facilities were designed, constructed, owned, and operated by MCWD with a capacity sufficient to convey the 5,127 afy of advance treated water and wherein MCWD will have the right to utilize up to and including a net 1,427 afy of the AWPF's treatment capacity to serve the Ord Community and to implement the recycled water portion of the Regional Urban Water Augmentation Program. As shown in Table 4.10, the project is expected to provide 600 afy in 2025, and increase to 1,359 afy in 2030. The project functions as an in-lieu groundwater recharge project and will be a major component of any groundwater sustainability plan for the Marina Area.

MCWD is considering indirect potable reuse of advanced treated water as an alternative to the desalination portion of the RUWAP (similar to the Pure Water Monterey injection in the Seaside Groundwater Basin). The injection wellfield would be located within the Ord Community, up-gradient of the District's wells.

Figure 5.11 Pure Water Monterey Schematic (partial)

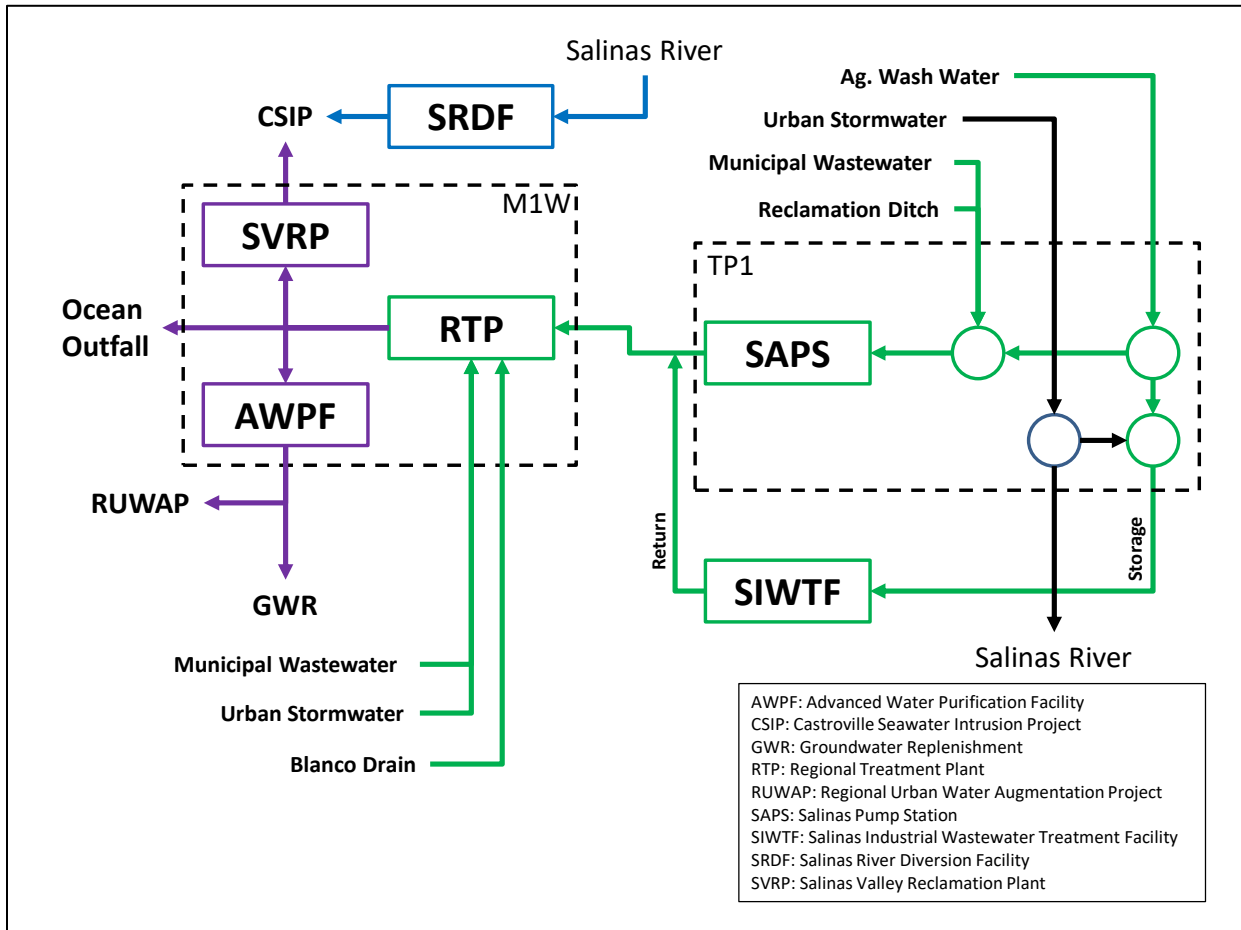
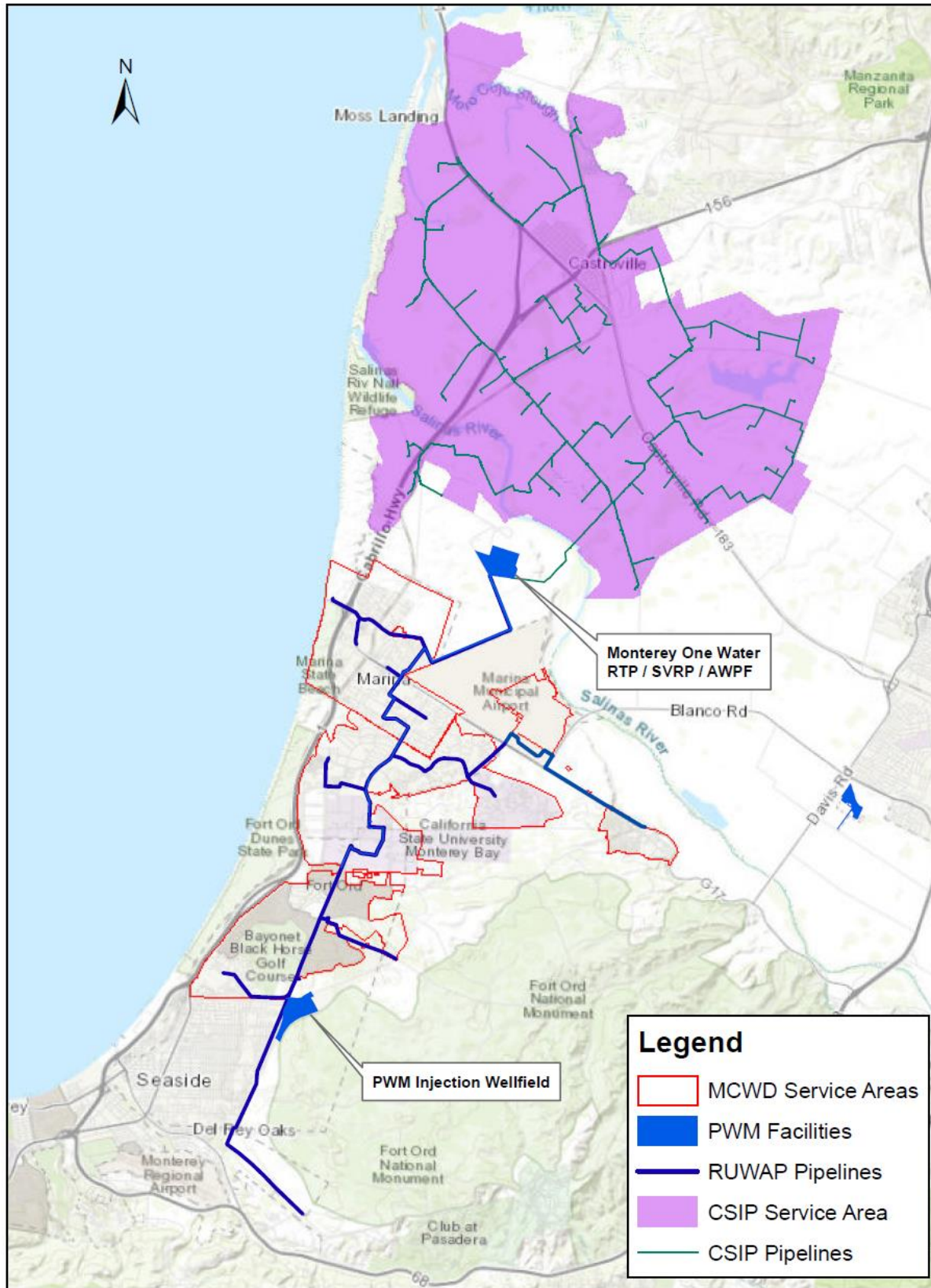

Figure 5.12 Recycled Water Systems



5.6 Desalinated Water

5.6.1 Existing Desalination Facilities

In 1996, MCWD constructed a seawater desalination facility to explore the feasibility of extracting seawater through shallow wells along the beach. This small seawater desalination plant is located at the former wastewater treatment plant site on Reservation Road between Dunes Drive and the Monterey Bay. The source water for the plant came from a shallow well³⁵ located on Marina State Beach. This was constructed as a pilot facility (300 afy), used to verify that adequate seawater supply could be produced from beach wells, and to test the use of beach injection wells for the disposal of brine (the salty water that remains after potable supply is separated from seawater using reverse osmosis). The Monterey Bay is a national marine sanctuary, so open ocean intakes and discharges were not allowed. This plant is no longer in service.

A similarly-sized desalination plant (300 afy) was constructed in Sand City in 2010, using multiple wells for groundwater extraction and brine disposal. This is the first coastal desalination facility permitted since the Monterey Bay was designated a national marine sanctuary. The plant is operated by California American Water Company as part of their Monterey Service Area. These plants, along with the locations of proposed desalination facilities, are shown on Figure 5.13, which appears at the end of the desalination section.

5.6.2 Planned Desalination Facilities

Under the Regional Urban Water Augmentation Project, MCWD evaluated replacing the pilot plant with a larger facility capable of producing up to 3,000 afy of potable water per year. Of the 3,000 afy, 2,400 afy was proposed to augment the future needs of Ord Community, 300 afy was replacement for the current plant's capacity; and an additional 300 afy was considered to help satisfy demands on the Monterey Peninsula, outside of MCWD's service area. In the final EIR for the Regional Urban Water Augmentation Project, the desalination portion was reduced to 1,500 afy, with 1,200 afy for the Ord Community and 300 afy to replace the existing Central Marina plant.

In 2007, a Desalination Facility Basis of Design Report was published for the RUWAP desalination component. That study analyzed locating the 1,500 afy plant at the former Fort Ord Main Garrison Wastewater Treatment Plant. That facility, located on the coastal side of Highway 1, has been inactive since the sewer system was connected to the M1W regional interceptor in 1990. Aside from reusing an existing disturbed site, the proposed location was preferred over the existing desalination plant location due to its set-back from the coastal bluff. The coastal bluff along that portion of the Monterey Bay experiences from 3.6 to 6.6 feet of

³⁵ Intake well completed to 90-ft below ground surface.

erosion per year³⁶, so locating the facility further from it extends its estimated service life. Vertical water wells would be drilled into the 180-ft aquifer and/or the shallow aquifer to supply seawater-intruded groundwater. Water treatment would consist of desalination using reverse-osmosis (RO), followed by conventional disinfection. Product water would be pumped into the existing municipal distribution system. The brine from the RO treatment system would be blended with additional water from the source wells, and then disposed of using wells or infiltration galleries in the coastal dune.

In 2006, California American Water Company (CAW) began the preliminary design of their Coastal Water Project (CWP), which would provide up to 11 million gallons per day (12,320 afy) of desalinated water for their Monterey Service Area, in order to reduce withdrawals from the Carmel River and the Seaside groundwater basin. CAW had been ordered to reduce pumping from the river under State Water Resources Control Board Order 95-10. Two plant sites were considered, one in Moss Landing at the former National Refractory site, and one in North Marina adjacent to the Monterey One Water regional wastewater treatment plant. The M1W site was preferred because of the existing deep ocean outfall that may be used for brine disposal. Seeing an opportunity for efficiency through combined efforts, MCWD, CAW, MCWRA and CPUC worked cooperatively to study and include a regional desalination facility in the CWP EIR as an alternative project to the CAW-only desalination facility. MCWD had a pre-existing purchase option for land adjacent to the M1W plant, which facilitated an agreement between the two agencies. The shared Regional Desalination Facility was certified as the environmentally superior alternative in the Final Coastal Water Project EIR adopted by the California Public Utilities Commission – Division of Ratepayer Advocates (CPUC-DRA). MCWD subsequently purchased the land for the plant.

In 2010, MCWD entered into an agreement with the MCWRA and CAW to jointly develop the Regional Desalination Facility, to be located adjacent to the M1W treatment plant with an initial capacity of 10 mgd. The source water for the plant was to be seawater-intruded groundwater from the 180-Foot Aquifer. This provides a source of supply that does not involve an open ocean intake. Under that agreement, MCWRA would construct and operate the well-field, MCWD would construct and operate the treatment plant and a portion of the transmission pipeline, and CAW would construct the remainder of the transmission main. Because a portion of this supply is Salinas Valley groundwater which cannot be provided to customers outside MCWRA Zones 2/2A, MCWD would take that portion of the plant yield and reduce pumping from their existing wells. CAW would initially take the full desalinated seawater yield. When the potable demands in the Ord Community exceed the available groundwater allocation, MCWD may take desalinated seawater (in addition to the groundwater component), up to the

³⁶ Engeo Memorandum: Assessment of Erosion Rates, MCWD Regional Water Augmentation Desalination Plant, October 30, 2006

limits established in the CWP EIR. Due to litigation over the validity of inter-agency agreements, the parties are no longer jointly pursuing the Regional Desalination Project.

CAW is currently pursuing the Monterey Peninsula Water Supply Project, which includes a 9.6 mgd seawater desalination facility located near the MIW regional plant. CAW is proposing that the source water for this facility would come from slant wells on the CEMEX property within the North Marina Area. Water treatment would be by reverse osmosis, and brine disposal would be through the MIW ocean outfall, just as in the Regional Desalination Facility. A test slant well was constructed in 2015, and underwent intermittent testing from April 2015 through March 2018. The CPUC has approved the project, but the California Coastal Commission has not yet approved the project. As with the Regional Desalination Project, the portion of the supply from Salinas Valley Groundwater would need to remain in the Salinas Valley, going to the Castroville community and the CSIP irrigation system. MCWD has expressed concerns that the project as proposed will adversely impact water levels and water quality in the North Marina Area and Marina Area Subbasin, resulting in potential adverse impacts to MCWD's wells.

One additional project being considered in Monterey County is DeepWater Desal LLC's Monterey Bay Regional Water Project, located in Moss Landing. The project does not have a local public agency as a sponsor, so the State Lands Commission would be the CEQA lead agency for the environmental review. A notice of preparation was issued for the project in June 2015 with this description: "A proposed 25,000 acre-feet per year seawater reverse osmosis desalination facility and co-located seawater-cooled 150-megawatt computer data center campus located on a 110-acre site approximately 1.5 miles east of Moss Landing in Monterey County, California. The Project would also include seawater intake and brine discharge pipelines that would extend west from Moss Landing Harbor to the upper reaches of the submarine Monterey Canyon and the north shelf, respectively, within Monterey Bay National Marine Sanctuary." The project is intended to provide wholesale water supply to cities and agencies in both Monterey and Santa Cruz Counties. The Draft EIR has not yet been issued for public review and comment.

Figure 5.13 Existing and Potential Desalination Facilities

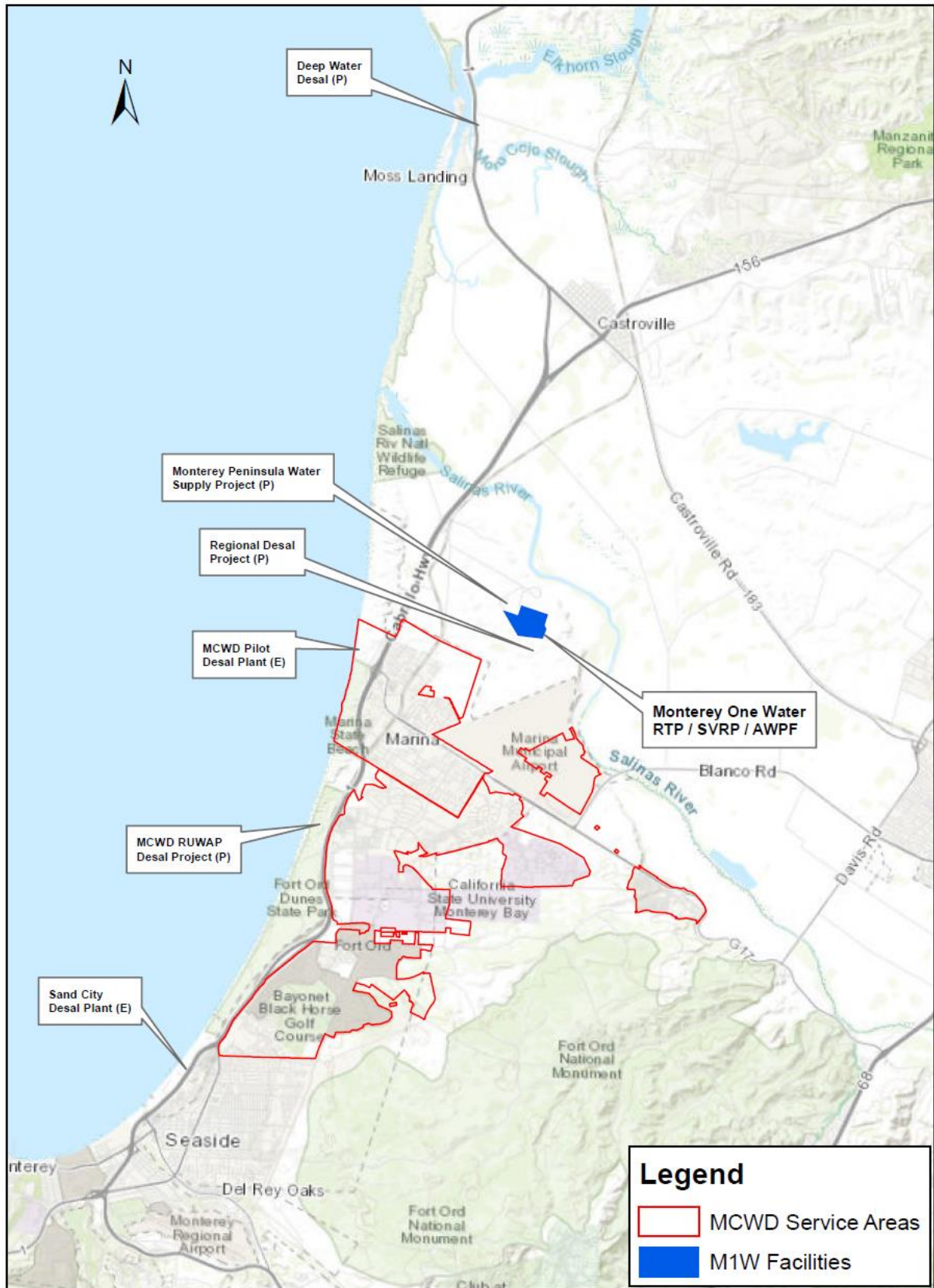

Section 6 - Water Supply Reliability and Water Shortage Contingency Planning

6.1 Water Supply Reliability - Single and Multiple Dry Years

The Urban Water Management Planning Act requires a description of a water provider's supply reliability and vulnerability to shortage for an average water year, a single dry year or multiple dry years. Such analysis is most clearly relevant to water systems that are supplied by surface water. Since the bulk of MCWD's supply is groundwater and the remainder will come from recycled and desalinated supply, short- and medium-term hydrologic events over a period of less than five years usually have little bearing on water availability. The Salinas Valley Groundwater Basin has about 19.8 million acre-feet of storage capacity, and was estimated to hold 16.4 million acre-feet in 2013³⁷. Annual water use from the SVGB is approximately 0.5 million AFY. Within the 180/400 Foot Aquifer Subbasin, storage was estimated to be 6.8 million acre-feet. The Salinas Basin is aided by two large storage reservoirs, Nacimiento and San Antonio, providing about 700,000 ac-ft of storage. These reservoirs regulate surface water inflow to the basin shifting winter flows into spring and summer releases for consumptive use, which also allows for increased basin recharge. The Salinas Valley Water Project has reduced groundwater pumping in the 180/400 Foot Aquifer Subbasin. Therefore, MCWD's groundwater supply is fully available in annual average, single dry year and multiple dry years.

Water demands within the District do vary with weather changes and under drought-year restrictions. The single driest year on record is 2013, with a record low rainfall of 3.3 inches at the Salinas Airport rain gage. Water use within the District increased from 4,173 afy in 2012 to 4,431 afy in 2013 (drought restrictions were not implemented until 2014). The water use increased by 6% over an average weather year, with the majority of the increase being irrigation of the Bayonet/Blackhorse Golf Course.

The driest three-year period on record was 1988-1990, with 21.7 inches of rainfall recorded at the Salinas Airport. Water usage records for that period were not available, so the second-driest period of record was used for the multiple dry year analysis: 2013-2015, with 23.2 inches of recorded rainfall. In 2013, the Governor and the State Water Resources Control Board identified the start of an extended drought, and in 2014 they mandated state-wide water conservation measures. As a result of the mandated conservation, the District's water demand declined to 4,026 afy in 2014, and 3,228 afy in 2015. A portion of that demand reduction was due to the Bayonet/Blackhorse Golf Course transitioning from MCWD supply to Seaside Groundwater Basin wells in 2015.

³⁷ Brown & Caldwell, State of the Salinas River Groundwater Basin, 2015

To estimate the water demand changes during a five-year drought, the actual water use from 2013-2017 is compared to 2012. Water usage for the golf course is removed from the system total, since that high-volume customer was not supplied by the District for the full analysis period, and in the future will be supplied using recycled water. The District declared Water Conservation Stage 1 in February 2014, and increased it to Water Conservation Stage 3 in November 2014 to meet the State mandated restrictions on landscape watering. In August 2016 the District reduced to Water Conservation Stage 2. The service area population is estimated to have increased by 10% during that 5-year period as new homes were being constructed in the Ord Community. As shown below, water demand increased by 2% over average in the first year, declined to 90% in the second year and to 78% in the fourth year. The restrictions on landscape watering did not apply in 2017, so we will assume that in a 5th consecutive drought year with landscape watering restrictions, the use will be 78% of average, as in the 4th Year.

Table 6.1 Multiple Dry-Year Demand Adjustment Factors

Year	2012	2013	2014	2015	2016	2017
Year Type	Average	1 st Dry*	2 nd Dry	3 rd Dry	4 th Dry	Average
Water Use (afy)	4,174	4,431	4,026	3,228	3,025	3,239
Golf Course Irrig. (afy)	264	456	524	138	0	0
Net w/o Golf Irrig. (afy)	3,909	3,975	3,502	3,090	3,025	3,239
Factor	100%	102%	90%	79%	78%	83%

* 2013 is the single driest year on record

Using the above factors, the District's projected water demands can be scaled to estimate drought response. The total projected demands are shown in Table 6.2. Because the demand is projected to decline under a multiple-year drought and the available groundwater storage greatly exceeds even a five-year demand, the available water supply is considered reliable in all years.

Table 6.2 Water Demands in Single and Multiple Dry Years

Year-Type	2020	2025	2030	2035	2040
Average	3,367	5,991	7,792	8,869	9,574
Single-Dry	3,434	6,111	7,948	9,046	9,765
Multiple Dry 1st Year	3,434	6,111	7,948	9,046	9,765
Multiple Dry 2nd Year	3,030	5,392	7,013	7,982	8,616
Multiple Dry 3rd Year	2,660	4,733	6,156	7,006	7,563
Multiple Dry 4th Year	2,593	4,613	6,000	6,829	7,372
Multiple Dry 5th Year	2,593	4,613	6,000	6,829	7,372

6.2 Water Quality Impacts on Reliability

The reliability of MCWD's water supplies relative to seawater intrusion and groundwater contamination are discussed at length in Section 5.2.5. Water quality and contamination monitoring programs are discussed in Section 5.2.6. While neither seawater intrusion nor groundwater contamination pose an immediate threat to water supply reliability, MCWD

maintains active monitoring of intrusion and contamination status and participates in the analytical and management efforts undertaken by the Monterey County Water Resources Agency with respect to seawater intrusion remediation actions and by the U. S. Army Corps of Engineers relative to groundwater cleanup on the former Fort Ord.

6.3 Water Quality Monitoring

Water quality monitoring and lab analysis is performed by Marina Coast Water District by its lab staff and under contract with state certified laboratories. Water samples from wells, water treatment plants, and point-of-use locations are collected and tested to assure water delivered to customers meets both state and federal standards. Results from water quality testing are published annually in MCWD's annual Consumer Confidence Report.³⁸ The quality of MCWD's water supplies meets the requirements of all current state and federal drinking water quality regulations.

Groundwater from the Marina and Ord water supply wells is disinfected with chlorine as a safeguard against microorganisms. In Marina, chlorine is also used to treat the naturally occurring sulfides at Well 12 that can cause odors.

MCWD's state-certified laboratory performs extensive water quality monitoring of the Marina and Ord drinking water supply. Regulations require weekly monitoring for coliform bacteria in the distribution system. The presence of coliform bacteria may indicate the presence of disease-causing organisms. One water sample from each of five sampling sites in Marina and from each of five in Ord is collected and analyzed each week. A different set of five is analyzed each week in a month for each water system. There are a total of 20 different sample sites in Marina and 20 different sample sites in the Ord Community from which water samples are collected.

To make sure that water quality is maintained from source to delivery, MCWD's laboratory also performs weekly monitoring of general physical and chemical parameters. Each week five water samples are collected from the Marina and Ord coliform sampling sites, from the Marina and Ord source wells and from the water reservoir in Marina. The water samples are tested for color, odor, turbidity, temperature, pH, conductivity, free chlorine residual and sulfides.

In addition, the Marina and Ord source wells are also tested for chloride, fluoride, nitrate, bromide and sulfate. The purpose of this monitoring is to detect any abnormal concentrations that might indicate problems within the system.

MCWD monitors for compliance over 110 constituents in drinking water in varying schedules. Many of these constituents are naturally occurring substances. The Marina and Ord source wells are tested for general minerals such as calcium, magnesium, hardness; inorganic chemicals such as arsenic, chromium and other metals; organic chemicals such as solvents, pesticides and

³⁸ See www.mcwd.org/water_quality.html.

herbicides; radioactivity including radon; asbestos and other chemicals that are still not regulated and have no state or federal standards. Regulations also require that MCWD test for disinfection (chlorination) by-products such as total trihalomethanes and haloacetic acids in the distribution system. Lead and copper are tested from indoor water samples to check if materials used in home or building plumbing contribute to levels of lead and copper.

6.4 Water Production System Reliability

MCWD has undertaken specific measures to ensure its ability to supply water in the event that groundwater production is impaired by mechanical failure or any other potential problem, including water quality impairment.

In 2005, MCWD connected the Marina and Ord water systems that had been operated separately (each with three wells) into a single, six-well system that can be operated in an integrated manner to ensure physical production reliability for the system as a whole. The connection added system redundancy, a basic emergency-response feature of many water systems. In 2007, MCWD combined the two water systems under a single permit from the California Department of Public Health.

In 2008-09, MCWD replaced the D-Zone water tank with a larger reservoir, and replaced the E-Zone reservoir with a hydropneumatic booster pump station. In 2011, the District added two new water wells in the Ord Community. The District is about to begin construction of two new 1.6 MG water tanks for the A-Zone and a new B/C Zones Booster Pump Station. The existing booster pump station was constructed in the early 1950s.

6.5 Water Shortage Contingency Plan

To prepare a water supplier for the event of a water shortage, including a drought or an emergency shortage, the Act requires an UWMP to include a Water Shortage Contingency Plan (WSCP). The WSCP needs to include the following specific elements:

- Actions to be undertaken by the water supplier to prepare for, and implement during, a catastrophic interruption of water suppliers (e.g., a regional power outage, an earthquake, or other disaster).
- Stages of action, including a reduction of over 50-percent of supply, and an outline of specific supply conditions at each stage.
- Additional, mandatory provisions against specific water use practices during water shortages (e.g., street cleaning).
- Consumption reduction methods in the most restrictive (drought) stages, up to a greater than 50 percent reduction in demand.
- Penalties or charges for excessive use, where applicable.

- An analysis of the impacts of each of the actions and conditions described in the WSCP on the revenues and expenditures of the urban water supplier and proposed measures to overcome those impacts.
- A draft water shortage contingency resolution or ordinance.
- Description of a mechanism for determining actual water use reductions pursuant to the WSCP.

The District Board of Directors adopted an updated Water Shortage Contingency Plan on July 6, 2015, in Resolution No. 2015-33. The WSCP includes specific restrictions on water use that may be implemented at the time of a water shortage. Stages of action and triggers were not changed from the previously adopted WSCP. The Resolution and WSCP are included in Appendix F. Article 3.36.050 of MCWD Code of Ordinances allows for enforcement of the WSCP.

6.5.1 Actions in the Event of a Catastrophic Interruption

MCWD developed and adopted an Emergency Response Plan (ERP) in 2007 for emergency and disaster occurrences with guidelines and agreements for cooperative efforts with other State and local agencies, as required by the State Department of Public Health. The ERP contains actions MCWD would initiate in the event of a catastrophic reduction in its water supply. Article 2.09, Local Emergency, of the District Code of Ordinances details the procedure for declaring an emergency and the procedures authorized for immediate response. MCWD conducts periodic table-top exercises with the emergency response offices of the jurisdictions it serves, and annual reviews of its emergency response plan.

6.5.2 Stages of Action, Mandatory Provisions, Reduction Methods

The District's Water Shortage Contingency Plan includes stages of action, mandatory provisions, and consumption reduction methods. Because the Salinas Valley Groundwater Basin has sufficient storage to whether a multiple-year drought, the triggers for the Stages of Action listed in Table 6.3 reflect mechanical failures and/or water quality concerns, which are more likely to impact MCWD. The mandatory provisions and consumption reduction methods for each stage are detailed in the Water Shortage Contingency Plan at Appendix F.

Table 6.3 Water Shortage Contingency Plan - Stages of Action

Stage No.	Water Supply Conditions			% Shortage
	System Malfunction	Exceed Chloride Standard?	VOC Standards	
1	10% shortage	Not threatened	Not exceeded w/blending	0 - 10
2	10% - 25% shortage	May be threatened	Not exceeded w/blending	10 - 25
3	25% - 35% shortage	Expected	Not exceeded w/blending <u>or</u> remaining capacity reduced by up to 25%	25 - 35
4	35% - 50% shortage	Expected	Not exceeded w/blending <u>or</u> remaining capacity reduced by up to 35%	35 - 50
5	>50% shortage	Expected	Not exceeded w/blending <u>or</u> remaining capacity reduced by up to 50%	>50
Stages 1-5 may also be declared upon directive from the State of California or the County of Monterey to implement demand reduction measures in response to drought conditions				

6.5.3 Penalties or Charges for Excessive Use

Article 3.36.050 of District Code of Ordinances provides for a system of notices and fees for violations. Article 3.36.060 also allows for recovery of costs incurred abating a violation. Violation of provisions of the WSCP shall be enforced under these parts of the MCWD Code.

Table 6.4 summarizes the penalties and charges detailed in Article 3.36.050. The Code does not currently include more stringent penalties or charges for higher stages of a water shortage, but the Board of Directors may consider additional penalties if an extended shortage should occur. Section 4 of the WSCP includes procedures for making appeals to the Board for relaxation of water use restrictions.

Table 6.4 Water Shortage Contingency – Penalties and Charges

Penalties or Charges	Stage When Penalty Takes Effect
<i>Penalty for excess use:</i> Written notice, date for correction	Applicable to all stages (i.e., not stage-specific)
<i>Charge for excess use:</i> \$100 administrative fee for 1 st notice; \$200 for 2 nd notice; \$500 for each additional violation within one (1) year.	
<i>Other:</i> Costs of abatement	
<i>Other:</i> Costs of enforcement	
<i>Other:</i> Civil penalty of 50% of abatement and enforcement costs.	

6.5.4 Revenue and Expenditure Impacts

Enforcement of the Water Shortage Contingency Plan is assumed to be covered by enhanced revenues from application of excess use charges and penalties. District reserves may be used temporarily should revenues remain below expectations. MCWD's rate structure is based upon adopted rate ranges and allows for modification of rates on short notice within those ranges. MCWD retains the ability to modify rates to meet all legitimate District needs. Revenue impacts from water sales losses are estimated as follows, based upon Tier 2 rates of \$5.15/hundred cubic feet (hcf) in Central Marina and \$8.51/hcf in the Ord Community for the first 30% reduction, and Tier 1 rates of \$3.38/hcf and 4.37/hcf, respectively, for the additional reductions above 30%. Note that the calculation assumes a full calendar year of reduced use, so only the percent reduction would be applicable to short-term restrictions.

Table 6.5 Potential Revenue Impacts of Implementation of WSCP

	Stage 1	Stage 2	Stage 3	Stage 4	Stage 5
Assumed Reduction	10 percent	20 percent	30 percent	40 percent	50 percent
Water Sales Loss	\$999,602	\$1,999,203	\$2,998,805	\$3,560,668	\$4,122,532
Revenue Source: Pumping savings at \$140/af	\$46,130	\$92,260	\$138,390	\$184,520	\$230,650
Net Revenue Reduction	\$953,472	\$1,906,943	\$2,860,415	\$3,376,148	\$3,891,882
Percent of Total Annual Water System Revenue	8%	16%	25%	29%	33%

* Table based on FY2019-20 water sales, \$11,652,404 for 3,295 acre-feet

6.5.5 Mechanism to Determine Actual Water Use Reductions

Implementing the WSCP is intended to reduce water use to levels specified by stage. Crucial to the implementation is determining how effective any enacted measures are in actually reducing water use.

The WSCP includes increasingly frequent reporting of water usage, based on daily O&M recording of production figures, to the MCWD Board per increasingly severe stages. The monitoring, reporting, and subsequent analyses are meant to determine the extent of water use reductions. Furthermore, the WSCP includes provisions for the MCWD Board to alter WSCP actions at each stage (i.e., tighten restrictions) if usage reduction targets are not being met. Essentially, a feedback loop of monitoring, reporting, and action will be used to effectively implement the WSCP.

6.6 Seismic Risks to Water Supply

The Salinas Valley Groundwater Basin is not crossed by major faults and not considered at risk of changing characteristics during a seismic event. If an earthquake occurs, the primary risk is

damage to water system equipment (wells, tanks and pump stations). The District has a detailed emergency response plan. A summary Technical Memorandum addressing the mitigations and responses by equipment type is provided in Appendix E.

The County has two reservoirs in the upper Salinas Valley which provide both flood protection and water supply, Nacimiento and San Antonio Reservoirs. Releases from these reservoirs augment groundwater recharge and provide supply for crop irrigation. These dams were assessed in the Monterey County Multi-Jurisdiction Hazard Mitigation Plan to be at low risk of failure during a seismic event. The effects of an unlikely dam failure are included in the Seismic Risk technical memorandum in Appendix E.

6.7 Drought Planning

As discussed in Section 6.1, MCWRA has implemented several water supply projects to augment the Salinas Valley Groundwater Basin and make it less susceptible to be susceptible to drought. However, the District is pursuing two sources of new water supply that are not drought susceptible: desalination of seawater-intruded groundwater and urban use of recycled water. Both of these projects are discussed in Section 5.

6.8 Annual Water Supply and Demand Assessment

Water Code §10632(a)(2) requires water suppliers, beginning in 2022, to prepare an annual assessment of their projected demand and water supply reliability for the upcoming year. The District has not yet adopted formal procedures for preparing this assessment, but the required data inputs and methodologies will be as follows:

6.8.1 Evaluation Criteria

Criteria for evaluating the availability of groundwater supply will be the same as those used in Groundwater Sustainability Plan, as discussed in Section 5.2.2.

6.8.2 Water Supply

As discussed in Section 6.1, the Salinas Valley Groundwater Basin has a large storage volume which provides a buffer during periods of drought. Unless there is a water quality issue, the District can reliably meet their water demands with groundwater in any given year.

The District will begin supplying recycled water to customers within the next several years. As this supply will be a wholesale purchase from Monterey One Water, the assessment of recycled water availability should be provided by M1W.

6.8.3 Current Year Unconstrained Customer Demand

The Ord Community is still undergoing redevelopment, so it would not be unreasonable to assume the current year demand at 5% greater than the previous year's demand. This is conservatively high based on the current redevelopment rates.

6.8.4 Current Year Supply

Groundwater supply would be considered available, up to the limits established in the Zone 2/2A annexations, unless other pumping limitation are established in a Groundwater Sustainability Plan.

Recycled water supply projections would be provided by M1W. If the projected recycled water supply is less than the projected demand, the District must account for providing groundwater to make up the difference.

6.8.5 Infrastructure Considerations

Availability of supply may be affected by major infrastructure outages such as wells or transmission pipelines. These are not typical but may persist for several years after a natural disaster (earthquake or wildfire). If a water quality issue arises requiring water treatment, the availability of the treatment system may affect reliability. Final, the redevelopment of the Ord Community is not proceeding in a linear fashion, so there may be a projected demand in the coming year located where the District does not have the infrastructure to support it.

6.8.6 Other Factors

A consideration within the Ord Community is the sub-allocation of water supply to developments, and the tracking of water use within the development to verify they are within their sub-allocated limit. It is possible that a development may run out of water before it runs out of home lots. Such cases would be addressed by the District, Developer and the City or Land Use Jurisdiction working together.

Section 7 - Conservation and Demand Management Measures

7.1 Introduction

Water conservation is defined as any action taken to reduce water consumption or loss of available supply for use, such as leaks in the production and delivery system prior to the customer's meter. Demand management refers to a subset of conservation methods a water supplier may undertake to reduce demand on the water system. The Urban Water Management Planning Act requires that Retail Agencies report on six more general requirements plus an "other" category.

7.2 Demand Management Measures Implementation

The Urban Water Management Planning Act under California Water Code Section 10631 (f)(1) requires a description of a water supplier's water demand management measures that are being implemented or are scheduled for implementation. MCWD is continually seeking to improve its conservation program and features that are cost-effective or otherwise are a wise investment in resource management. The District completed its Urban Water Conservation Feasibility Study in 2004, and has been implementing the recommendations by phases. In 2015, The District added an additional Water Conservation Specialist position to the staff, which greatly increased their capacity for customer assistance.

MCWD signed the California Urban Water Conservation Council (CUWCC) MOU in 1991 and began implementing water conservation and demand management practices as part of its overall integrated water management program. Due to staffing changes, the District is behind on submitting CUWCC BMP Reports, with the last report submission made in 2010. Table 7.1 summarizes MCWD's water conservation program over the past 5 years and highlights the 2015 activities. Figure 7.1 shows the conservation program spending over the past five fiscal years and the indoor water usage during those years. Figure 7.2 shows spending and outdoor water usage over that same time period. Note that most residential irrigation is through domestic meters and therefore reflected in Figure 7.1. Also, conservation education spending appears in both graphs.

Mandatory restrictions on water use were implemented in 2014 in response to the state-wide drought. MCWD focused on education and outreach as it pertains to drought restrictions and was able to reduce outdoor water usage to below pre-drought levels. The primary programs contributing to this were landscape watering restrictions, the state requirement to let roadway medians to go fallow, and increased toilet and fixture retrofits. Post-drought water demand did not rebound to pre-drought levels, due to the effectiveness of retrofitting landscapes and indoor fixtures.

Table 7.1 Summary of DMM Implementation

Demand Management Measure	5-Year Program	2020 Activity
Water Waste Prohibition	On-going monitoring for violations	District has a water waste reporting webpage, and responds to vents as reported.
Metering with Commodity Rates	Last of the flat rate accounts were metered in 2019. On-going maintenance of existing AMR meters.	Ongoing maintenance. Staff notifies customers of AMR leak detections.
Conservation Pricing	Tiered commodity rates adopted annually as part of annual budget process.	Recently adjusted the pricing tiers from 3 to 2.
Public Information	Water conservation commission meets monthly. E-flyers are distributed monthly. Brochures are included with monthly billing	Printing budget increased for education materials. Customer e-mail list is maintained. Frequency of E-flyers increased
School Education	Funded in-school program for K-3 students through MPUSD	In-school appearances limited due to COVID-19. Offered remote learning/online class and school assemblies.
System Water Audits, Leak Detection, Repair	Annual prescreening system audit. Staff contacts customers when alerted by AMR loss detectors.	Conducted large meter testing and replacement. Efforts to improve and validate water loss data is on-going.
Conservation Staffing	Three positions authorized and two funded in FY19/20	Staffing remains funded at 2 positions plus one intern position in FY 20/21
Water Survey Programs for Residential Water Customers	On-site surveys performed by request. Compliance inspections are required upon transfer of property.	Developed residential self-survey for use during COVID-19. 185 residential surveys completed. Staff continues to perform outdoor landscape surveys.
Residential Plumbing Retrofits	Residential plumbing retrofits program included in annual budget (shower heads, leak detector kits, rebate budgets).	Free devices provided. Promotional efforts are on-going.
Residential Ultra Low Flow Toilet Replacement	MCWD continues to increase the budget to meet increasing demand for rebates.	208 units retrofitted with 268 ULFT in 2020.
High-Efficiency Washing Machine Financial Incentives	MCWD continues to increase the budget to meet increasing demand for rebates.	54 rebates approved
Commercial Industrial and Institutional Water Conservation	On-site surveys performed by request. All rebate programs available to CII customers.	No surveys requested due to COVID-19 restrictions. Assistance with leaks and notifications of high usage was on-going.
Large Landscape Conservation	On-site surveys performed by request. Rebate programs for controllers, drip systems, and turf replacement.	High usage monitored monthly. Notification and assistance with leaks and high use is on-going. Water use/water budget analysis provided to large users.

Figure 7.1 Conservation Spending and Indoor Water Demand

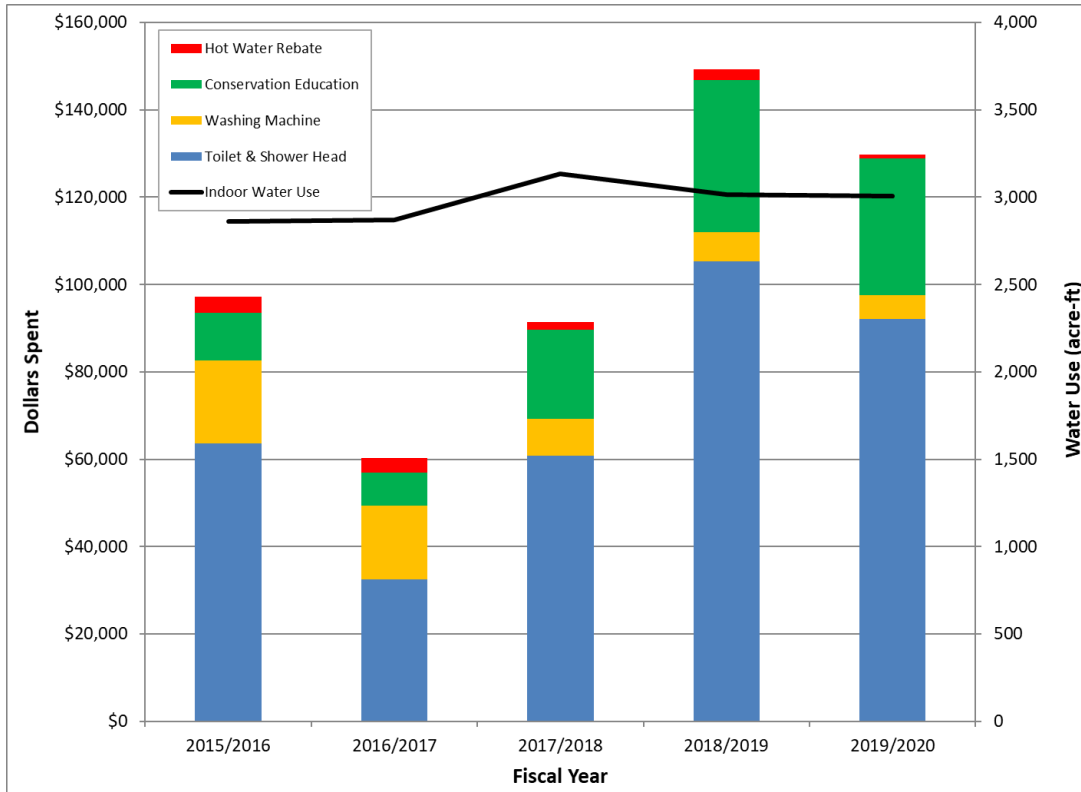

Figure 7.2 Conservation Spending and Outdoor Water Demand



7.2.1 Water Waste Prevention Ordinances

In 1993 MCWD enacted an ordinance addressing water waste and establishing limitations on how and when watering/irrigation can occur, and how water can be used outside (Section 3.36.030 of the District Code of Ordinances). This section of District Code was updated in 2004 and 2005 to add additional restrictions and incorporate the Model Water Efficient Landscape Ordinance. The 2015 update to the Model Water Efficient Landscape Ordinance adopted by the Legislature is incorporated by reference into the District Code.

Sections 3.36.040 through 3.36.060 of the District Code address enforcement of the waste prevention ordinances.

7.2.2 Metering

Meters are required as a matter of state law and urban water providers such as the MCWD have until January of 2025 to be fully metered. Meters with automatic meter reading (AMR) are being installed throughout MCWD in a phased program, and required for all new customers. A feature of the AMR equipment is that each meter will identify if water is used for continuous periods in excess of two hours. Once alerted, District staff contacts the customer, informs them of the possible leak and schedules a follow-up assistance visit, if requested. This has reduced the cost of water losses on the customer's side of the meter. The last flat-rate account was converted in 2019, so the District is now 100% metered.

7.2.3 Conservation Pricing

Water conservation is encouraged through a pricing system that rewards customers who use less water with financial incentives, while high water users are charged a higher rate. MCWD charges customers a fixed monthly fee (meter or ready-to-serve fee) and a commodity charge for water used. The commodity rates are on a tiered scale, as shown in Table 7.2. The Central Marina and Ord Community service areas are operated as separate cost centers and have different customer fee schedules. The water rate tiers and prices are reviewed annually during the budget review and approval process.

Table 7.2 Conservation Pricing Tiers (2021)

Tier	Consumption (hcf)	Ord Rate (per hcf)	Marina (per hcf)
First Tier	0-10	4.54	3.51
Second Tier	10+	8.84	5.57

hcf = hundred cubic feet

Conservation pricing is often cited as a way to use market mechanisms to provide incentives for conservation. Water consumption, however, has a relatively inelastic demand relative to price, meaning as unit prices go up, unit demand does not correspond in a 1:1 linear fashion. This is due to a variety of factors. Only a portion of water use for a residence can be considered discretionary, generally a portion of landscape irrigation, excess showering periods and the like.

At the point discretionary use has been wrung out of the system due to marginal costs of water, another rate tier is unlikely to reap much conservation savings. Additionally, California's Proposition 218 requires water rates to be developed on a cost of service basis. In other words, the top tier of the water rate must have a reasonable relationship to the avoided cost of service for marginal supply. Since MCWD is contemplating relatively expensive marginal supplies to meet new demands, meeting this test is not a concern at this point.

7.2.4 Public Education and Outreach

MCWD provides water conservation information to the public through a wide variety of public outreach tools: information booths at conferences, fairs and community events; flyers, newsletters and billing inserts; e-mailed announcements; video; website; and printed material to the media. MCWD has also partnered with the Water Awareness Committee of Monterey, California American Water Company and the Monterey Peninsula Water Management District to develop and distribute outreach material. More details can be viewed on the MCWD's webpage:

<http://www.mcwd.org/conserves.html>

The District Board appoints a standing Water Conservation Commission, made up of six members of the public, one Board member and one member of Marina City Council. The commission meets monthly to review water conservation ordinances and policies, refinements/adjustments to the water conservation program, specifically conservation Best Management Practice implementation, outreach and educational programs, the conservation budget, and overall District conservation resources; equipment and technologies that promote water conservation; periodic newsletters, Consumer Confidence Reports, and other conservation outreach activities. Recommendations by the commission are presented to the Board of Directors for implementation and action. The commission plays a key role in informing the public about the District's conservation activities.

In addition, MCWD promotes water conservation within the local schools. The Water Conservation Educator position within the Monterey Peninsula Unified School District has been funded by MCWD, CAW and other water providers within the school district for the past 18 years. The program covered all students in grades K-3. In addition, MCWD provides educators with handouts, Internet links and classroom activities when requested. Current staff has visited science classes upon invitation from teachers.

7.2.5 Programs to Assess and Manage Distribution System Real Loss

MCWD performs an annual prescreening system audit and responds to leaks or known trouble spots to make repairs and replacements as needed. The gross system loss for CY 2020 was 190.3 acre-feet, or about 6% of the total water production. The audited loss report for 2020 has not yet been prepared. The audited loss for 2019 was 9%. The District has a policy of tracking unmetered water use within the work order management system, so that activities such as line flushing, hydrant testing and fire department training are accounted for. There are three fire

jurisdictions within the District's water service area (City of Marina, City of Seaside, and Presidio of Monterey) so accounting for hydrant use is an on-going effort.

MCWD also uses its Supervisory Control and Data Acquisition (SCADA) system to identify main breaks and system leaks in real time. The District's service area is predominantly coastal dune with sandy soils. Small water leaks percolate easily and can go unnoticed for long periods of time. Alarms alert the staff to overflowing water tanks and/or failing equipment. System operators monitor the operational patterns of wells, booster pumps and water tanks, and investigate when water use exceeds typical norms.

7.2.6 Water Conservation Program Coordination and Staffing Support

The MCWD water conservation staff consists of three positions, a water conservation coordinator and two water conservation specialists. The conservation coordinator position is currently unfunded. The two staff are responsible for oversight and implementation of water conservation practices. MCWD's water conservation specialists work closely with local, regional and state boards as well as the neighboring water districts to implement the DMMs that are effective for the community and to foster an effective working relationship and provide continuity among the programs.

7.2.7 Water Survey Programs for Residential Customers

MCWD sends a qualified water auditor to single-family and multi-family customer locations to audit water use. The survey includes both indoor and outdoor components. The indoor component includes checks for leaks, including toilets, faucets and meters; checking showerhead, toilet, aerator flow rates and offering/suggesting replacement of high-flow devices. The outdoor survey includes checks of the irrigation system and control timers, and review or development of a customer's irrigation schedule. MCWD requires a survey to be conducted upon transfer of property ownership. MCWD also provides residential customer surveys on an "as-requested" basis, in addition to directly contacting the highest residential users and offering a survey. Any customer who is concerned about high water bills can request an on-site survey.

7.2.8 Residential Plumbing Retrofits

MCWD requires single and multi-family residences constructed prior to 1992 to be retrofitted with high-efficiency water fixtures, such as showerheads, faucets and toilets, if needed, upon resale (Article 3.36 of the Code of Ordinance). MCWD also requires low-flow fixtures in new construction and renovations. A walk-through inspection and conservation certification is required before occupancy by the new owner.

MCWD currently provides low-flow showerheads free of charge, and offers installation assistance. Article 3.36 of MCWD Code of Ordinances requires the installation of hot-water recirculation systems or point-of-use water heaters for new construction and renovation, which is

an additional water saving measure not required in the State Plumbing Code. The District offers rebates for those adding a hot-water recirculation pump as part of a renovation.

7.2.9 Residential Ultra-Low Flow Toilet Replacement Programs

MCWD's toilet replacement program offers a rebate for each toilet replaced with a high efficiency (1.28 gallon/flush) toilet. Over 3,000 toilets have been replaced under the program. Under the MCWD water waste ordinance, a residence must be completely retrofitted with ultra-low flow toilets (ULFTs) at the time of sale, and all new construction must install high efficiency toilets (HET) (1.28 gpf or dual flush). The District also provides rebates for waterless urinals. This program includes CII customers. Rebate rates are listed in Table 7.3, below.

Toilet replacement programs have generally been the most successful of demand management measures statewide. Savings for these programs have been shown to be 35-45 gallon per replacement per day, when retrofitting with 1.6 gal/flush units. Higher savings are found in higher density housing and commercial/industrial settings. Savings also persist as toilet life is generally about 25 years. The plumbing code allows for only 1.28 gal/flush or lower toilet models to be purchased, which will result in further savings over the 1.6 gal/flush retrofits of the last two decades.

7.2.10 High-Efficiency Washing Machine Rebate Programs

MCWD provides a rebate to customers who purchase high-efficiency (HE) clothes washers. The program is very successful, averaging 120 conversions each year. MCWD requires all new residential construction to include high efficiency washing machines in each unit, when washers are provided. The incremental cost of high efficiency washers (front loading, horizontal axis) has been about \$400 per unit over that of traditional, top load models. Typical customers can save from \$50 to \$100 per year in energy, water and waste water costs. Water savings range from 14 gallons per day in small single-family households up to over 100 gallons per day per unit in multi-family housing applications.³⁹

7.2.11 Commercial, Industrial, and Institutional Accounts

MCWD conducts water use surveys for Commercial, Industrial, and Institutional (CII) customers' indoor and outdoor water uses and the customer is provided with an evaluation of water using apparatus and processes and recommended efficiency measures, expected payback period and available agency incentives. CII customers are contacted within a year of the survey to discuss water use and water saving improvements based on the recommendations of the survey. All of MCWD rebate programs (toilet, landscape, clothes washer) are available to commercial as well as residential customers.

³⁹ California Urban Water Conservation Council, 2003.

7.2.12 Landscape Conservation Programs and Incentives

The purpose of this DMM is to provide customers with a determination of how much water should be used to irrigate the land appropriately while maintaining conservation practices. The program is oriented toward three groups of customers who irrigate landscapes: those with dedicated irrigation meters, those with meters who serve a mix of irrigation and non-landscape uses, and new accounts with irrigation use. Conservation staff conducts site reviews and assistance visits with property owners/property managers. MCWD has adopted the Model Water Efficient Landscape Ordinance, and requires formal review and approval of all landscapes 500 square-feet or larger.

MCWD has several programs for landscapes, including rebates for evapo-transpiration controllers, turf removal, moisture sensors, rain shut-off switches and drip irrigation systems. MCWD has two demonstration gardens with native drought-tolerant species, one in each service area.

The general public often views large landscapes as water conservation targets. Generally, however, and especially where dedicated irrigation meters exist, large landscapes are more efficiently managed than landscapes that are part of a mixed use setting. Large landscapes usually benefit from professional management and the owner's recognition of a direct correlation between the water bill and irrigation practices, which creates a financial incentive for conservation. Opportunity still exists to improve irrigation efficiency. The California Irrigation Management Information System (CIMIS) operated by the California Department of Water Resources provides real-time evapo-transpiration (ET) and other climatic data available on the Internet to help manage irrigation demands. CIMIS data can be combined with water budgets for each landscape to allow irrigation managers to apply only the amount of water needed. Newer irrigation controllers can either be programmed to modify irrigation schedules based on programmable ET factors, or query CIMIS stations for real-time data and be linked to soil moisture sensors and rain shut-off devices that can precisely provide only the amount of irrigation needed. These devices are now required per MCWD's design guidelines, and have been shown to produce from 25-45 percent in landscape water savings over traditional irrigation timers, which are often not reset to follow seasonal climate changes. Savings also accrue from the system's ability to automatically shut off irrigation zones when lines or sprinkler heads break or when there is significant rain. Such systems can also provide commercial or institutional customers with tremendous labor savings as they do not require human intervention to reset irrigation schedules to follow climate patterns or adjust for variations in precipitation. Savings can also accrue from lower fertilizer cost as off-site runoff can be eliminated.

Table 7.3 Current Rebates

Indoor Programs	Up to	Landscape Programs	Up to
High Efficiency Toilets		ET-Based Irrigation Controller	
1.28 gpf	\$50 each	System Conversion	\$150
1.28 gpf, entire property	\$75 each	Additional per Station	\$20 each
1.1 gpf	\$100 each	Rain/Moisture Shut-Off Switch	\$100 each
1.1 gpf, entire property	\$200 each	Lawn & Sprinkler Replacement	
Water-Free Urinal	\$200 each	Lawn replacement	\$1.00 SF
WF Urinal, entire property	\$300 each	Convert sprinkler to drip	\$0.50 SF
Clothes Washers		Rainwater Catchment	
3.5 to 3.8 gal/CF laundry	\$50 each	First 250 gallons	\$1.00 gallon
3.0 to 3.4 gal/CF laundry	\$100 each	Added storage up to 2500 gal.	\$0.50 gallon
Under 3.0 gal/CF laundry	\$150 each	Master Shut-Off Valve	\$100 each
Hot Water Recirc. System	\$250	Flow Sensor Rebate	\$100 each

7.3 Planned Implementation to Achieve Water Use Targets

MCWD has been active in promoting conservation and taking action to assure its implementation. Review of per capita demands for water indicates these efforts and resulting behavior of MCWD customers is having an effect. Per capita demand rates have been on a nearly consistent decline from an average of 144 gpcd in 1999 to 80 gpcd in 2020, which meets the District's 2020 water conservation target. As discussed in Section 4.4.1, per capita demand is projected to increase as commercial uses increase in the Ord Community. However, the planned addition of recycled water for urban landscape irrigation will address a portion of that increase.

The District will continue to track per capita demand rates to assess overall savings, in addition to comparing water consumption of new residential development against older households and households which have been retrofitted with conservation devices. The District will continually reassess rebate programs to address saturation rates and emerging technologies.

Conservation reductions have come primarily from improvements in water use technologies (low flow devices, irrigation controllers, etc.) and some from behavioral changes driven by increasing water rates, drought awareness, and public education programs. These long-term savings reduce the ability of the MCWD to call upon water use reductions if necessary due to curtailment of supply from groundwater. This is known as demand hardening. As demonstrated over the past two years, mandatory reductions in landscape irrigation will remain as the primary means of achieving short-term usage reductions during shortages.